

NOTES:

1. DRAWING TO BE INTERPRETED IN ACCORDANCE WITH THE CURRENT REVISION OF ASME Y14.5M.
2. TSI TO BE INTERPRETED AS THEORETICAL SHARP INTERSECTION.
3. PARTS SHALL BE FREE OF ALL CONTAMINANTS INCLUDING GREASE, DIRT, MACHINING OIL AND OTHER CONTAMINANTS.
4. PARTS SHALL BE PACKAGE IN A MANNER TO PREVENT BOWING, SCRATCHING, OR OTHER DAMAGE DURING SHIPMENT.

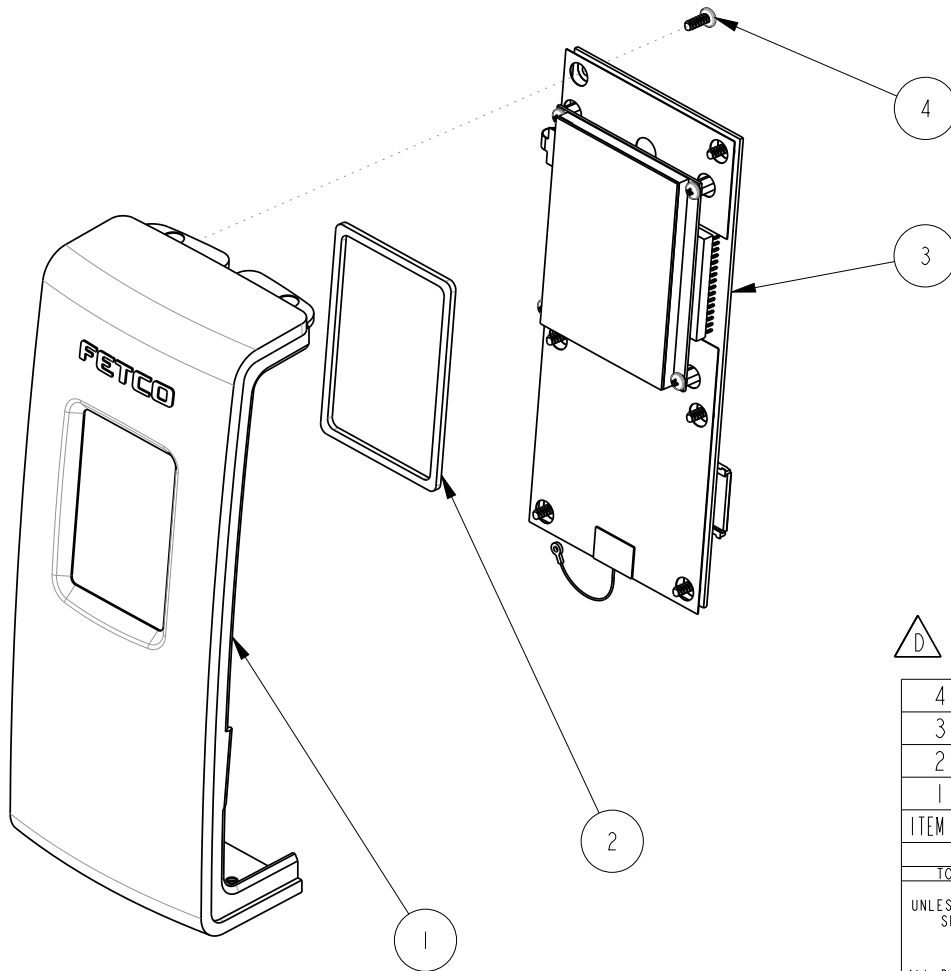

REVISIONS

REV	DATE	ECO NO	DESCRIPTION	BY:	D
A	07/11/2013	N/A	ORIGINAL	E.FORONDA	
B	12/20/2013	N/A	ADDED ITEM 4, 5 & 6, EMI SHIELD	E.FORONDA	
C	11/30/2016	N/A	RESTRUCTURE ASSY. TO REMOVE EMI SHIELD & SELF ADHESIVE TAPE	E.FORONDA	
D	01/27/2017	N/A	REMOVE ITEM 5	E.FORONDA	

MANUFACTURING NOTE:  
 APPLY A THIN BASE COATING,  
 ITEM 1097.00041.00, TO ITEM 2  
 FRONT & BACK FACE OF GASKET



ITEM NO	QTY	PART NO	DESCRIPTION
4	6	1082.00083.00	SCREW, #6-19 x 3/8", PAN HDTX, THRD FORM FOR PLASTIC, 18-8 SS
3	1	1102.00189.00	ASSEMBLY, TOUCH SCREEN, BOARD, CBS-2100
2	1	1024.00046.00	GASKET, TOUCH DISPLAY
1	1	1023.00160.00	FRONT PANEL

BILL OF MATERIALS			
TOLERANCES UNLESS OTHERWISE SPECIFIED		<b>FETCO</b> FOOD EQUIPMENT TECHNOLOGIES COMPANY 600 ROSE ROAD, LAKE ZURICH, IL 60047, USA PHONE: (800) 338-2699 FAX: (847) 719-3001 E-MAIL: engineering@fetco.com www.fetco.com	
ALL DIMENSIONS IN INCHES		DRAWING NAME: <b>ASSEMBLY, FRONT PANEL, CBS-2100 XTS</b>	
ALL DECIMAL ± .005" ANGULAR ± 1/2°		CREATED BY: E.FORONDA	DATE 07/11/2013
THIRD-ANGLE		DRAWING BY: E.FORONDA	SCALE 0.375
		APP'D BY: AG	DRAWING NO <b>1102.00210.00</b>
MATERIAL N/A		GUAGE N/A	REVISION <b>D</b>
		SHEETS 1 of 1	
		FINISH N/A	

PROPRIETARY AND CONFIDENTIAL.  
 THE INFORMATION CONTAINED IN THIS DRAWING IS THE SOLE PROPERTY OF FETCO.  
 ANY REPRODUCTION IN PART OR AS A WHOLE WITHOUT THE WRITTEN PERMISSION OF FETCO IS PROHIBITED.