

NOTES:

1. DRAWING TO BE INTERPRETED IN ACCORDANCE WITH THE CURRENT REVISION OF ASME Y14.5M.
2. TSI TO BE INTERPRETED AS THEORETICAL SHARP INTERSECTION
3. PARTS SHALL BE FREE OF ALL CONTAMINANTS INCLUDING GREASE, DIRT, MACHINING OIL AND OTHER CONTAMINANTS.
4. PARTS SHALL BE PACKAGED IN A MANNER TO PREVENT SCRATCHING, BOWING OR OTHER DAMAGE DURING SHIPMENT.

REVISIONS

REV	DATE	ECO NO	DESCRIPTION	BY:	D
A	03/07/2012	N/A	ORIGINAL	DK	
B	04/30/2012	N/A	1065.00005.00 REMOVED FROM ASSY	AG	
C	11/30/2016	N/A	ADDED P/N 1102.00367.00, EMI SHIELD	E.FORONDA	
D	01/27/2017	N/A	ADDED ITEM 6	E.FORONDA	

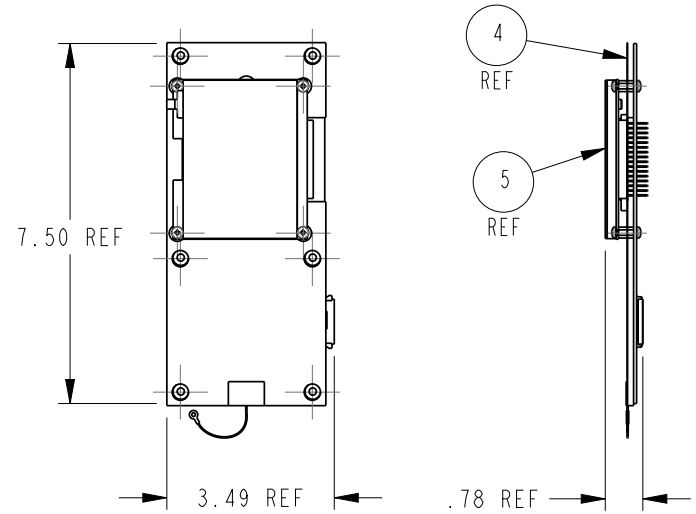
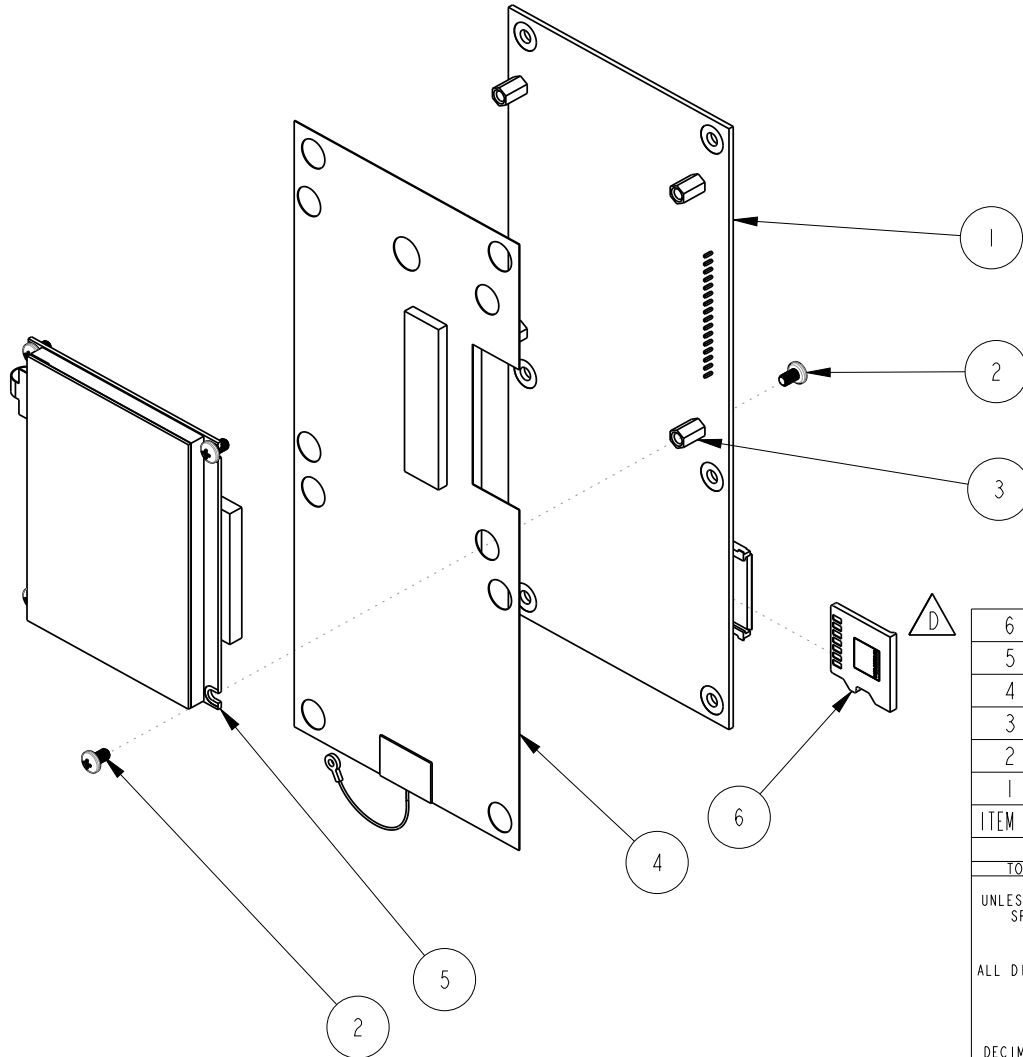

ITEM NO	QTY	PART NO	DESCRIPTION
6	1	1108.00035.00	SOFTWARE INSTALLATION, CBS-2100 XTS
5	1	1058.00021.00	DISPLAY, TOUCH SCREEN
4	1	1102.00367.00	ASSEMBLY, EMI SHIELD, CBS-2100
3	4	1084.00026.00	STANDOFF, M3-.5X8 MM FEM THRD, HEX NYLON
2	8	1082.00061.00	SCREW M3-.5 X 5MM, PAN HD PH, MACHINE, 18-8 SS
1	1	1051.00020.00	CONTROL BOARD, CBS-2100

BILL OF MATERIALS

TOLERANCES UNLESS OTHERWISE SPECIFIED	<b>FETCO</b> FOOD EQUIPMENT TECHNOLOGIES COMPANY 600 ROSE ROAD, LAKE ZURICH, IL 60047, USA PHONE: (800) 338-2699 FAX: (847) 719-3001 E-MAIL: engineering@fetco.com www.fetco.com		
	DRAWING NAME: <b>ASSEMBLY, TOUCH SCREEN, BOARD, CBS-2100</b>		
ALL DIMENSIONS IN INCHES	CREATED BY: DK	DATE 03/07/2012	DRAWING NO <b>1102.00189.00</b>
	DRAWING BY: DK	SCALE 0.500	REVISION <b>D</b>
ALL DECIMAL ± .005" ANGULAR ± 1/2°	APP'D BY: LMW	SHEETS 1 of 1	
THIRD-ANGLE	MATERIAL N/A	GAUGE N/A	FINISH N/A

PROPRIETARY AND CONFIDENTIAL.  
THE INFORMATION CONTAINED IN THIS DRAWING IS THE SOLE PROPERTY OF FETCO.  
ANY REPRODUCTION IN PART OR AS A WHOLE WITHOUT THE WRITTEN PERMISSION OF FETCO IS PROHIBITED.