

NOTES:

1. CHANGE OF MATERIAL IS NOT PERMITTED UNLESS APPROVED IN WRITING BY FETCO PERSONNEL.
2. DRAWING TO BE INTERPRETED IN ACCORDANCE WITH THE CURRENT REVISION OF ASME Y14.5M.
3. TSI TO BE INTERPRETED AS THEORETICAL SHARP INTERSECTION.
4. FLASH NOT TO EXCEED .005 UNLESS OTHERWISE STATED.
5. PARTING LINE AND EJECTOR MISMATCH SHALL NOT EXCEED .005 UNLESS OTHERWISE STATED.
6. ALL DIMENSIONS ARE MINUS DRAFT UNLESS OTHERWISE STATED.
7. USE OF MOLD RELEASE IS PROHIBITED UNLESS APPROVED IN WRITING BY FETCO ENGINEERING PERSONNEL.
8. TOOL DESIGN, INCLUDING GATE AND EJECTOR LOCATION, SHALL BE APPROVED BY FETCO ENGINEERING PERSONNEL PRIOR TO TOOLING FABRICATION.
9. PARTS SHALL BE PACKAGE IN A MANNER TO PREVENT BOWING, SCRATCHING, OR OTHER DAMAGE DURING SHIPMENT
10. PART, DATE & RECYCLE STAMPS ARE REQUIRED PER EACH PART

REVISIONS

REV	DATE	ECO NO	DESCRIPTION	BY:	B
A	07/14/2014	N/A	ORIGINAL	MK	
B	03/09/2015	N/A	ADDED PART IDENTIFICATION STAMP ON BACK SIDE	E.FORONDA	

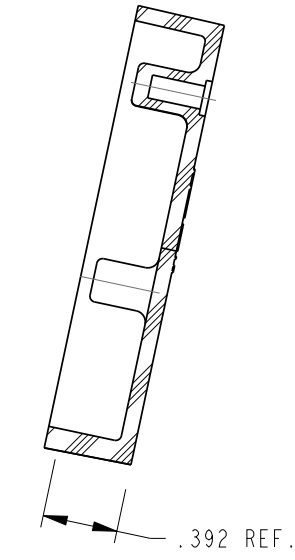
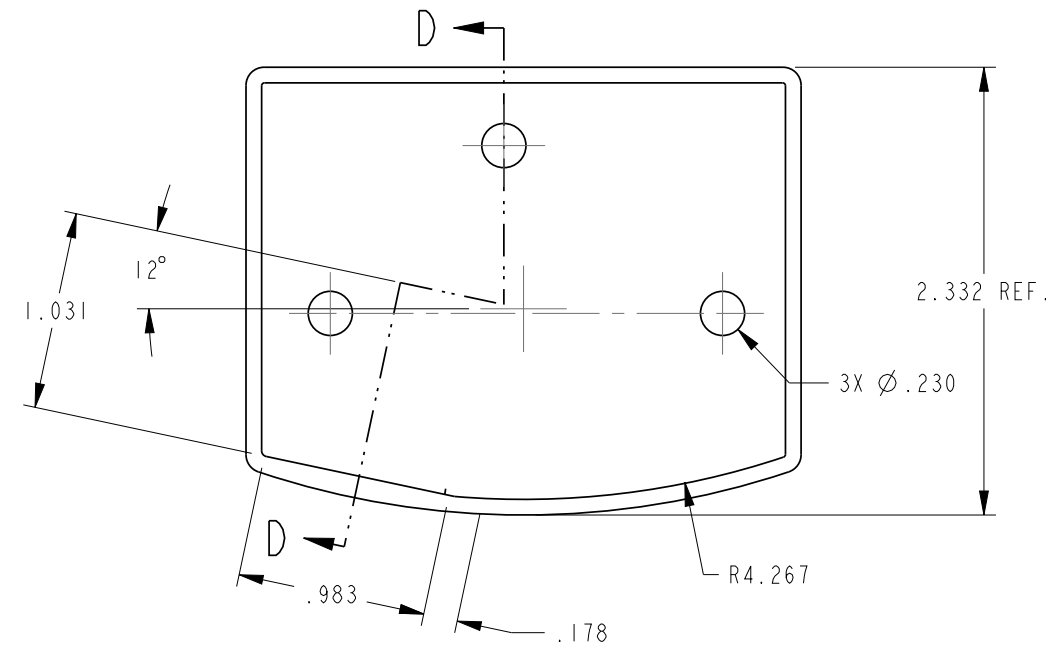
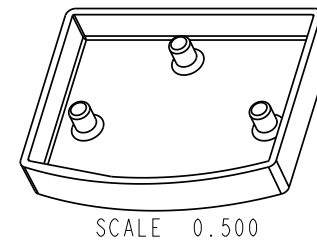

SECTION D-D

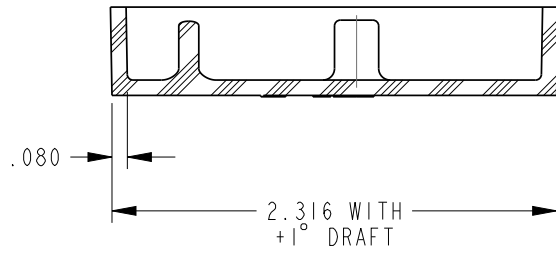

SECTION B-B

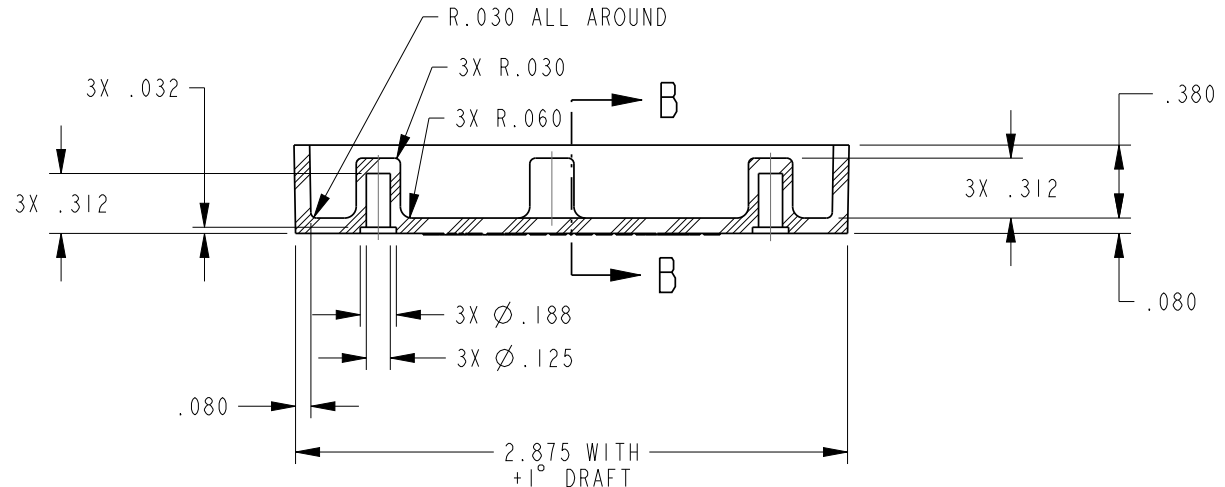

SECTION C-C

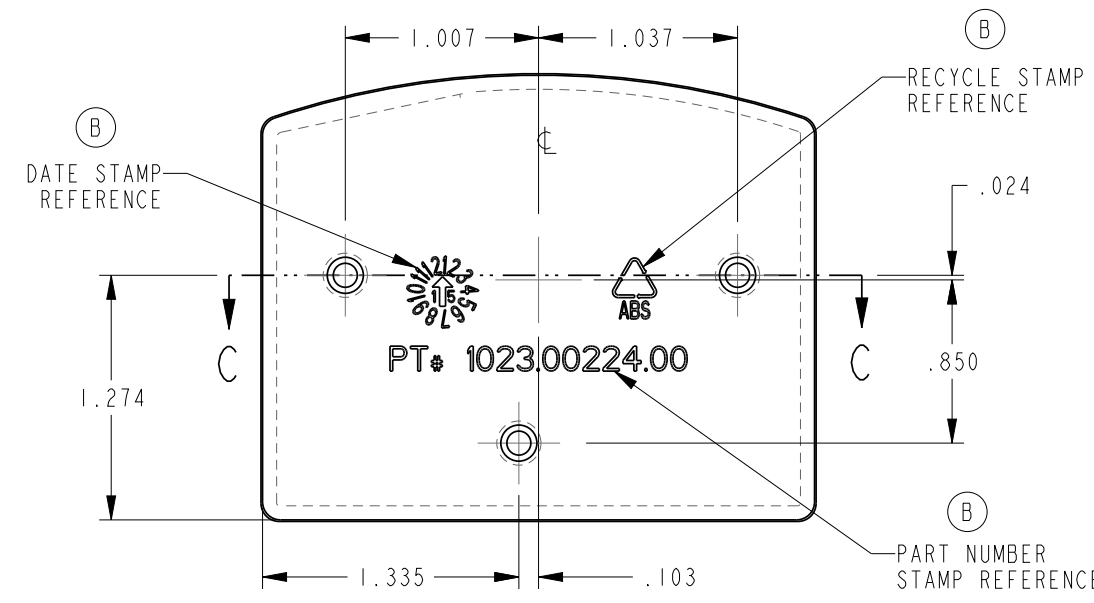

PROPRIETARY AND CONFIDENTIAL. THE INFORMATION CONTAINED IN THIS DRAWING IS THE SOLE PROPERTY OF FETCO. ANY REPRODUCTION IN PART OR AS A WHOLE WITHOUT THE WRITTEN PERMISSION OF FETCO IS PROHIBITED.

TOLERANCES		FETCO® FOOD EQUIPMENT TECHNOLOGIES COMPANY	
UNLESS OTHERWISE SPECIFIED		600 ROSE ROAD, LAKE ZURICH, IL 60047, USA PHONE: (800) 338-2699 FAX: (847) 719-3001 E-MAIL: engineering@fetco.com www.fetco.com	
DRAWING NAME: ELECTRONIC BOARD ENCLOSURE			
ALL DIMENSIONS IN INCHES	CREATED BY: MK	DATE: 07/14/2014	DRAWING NO. 1023.00224.00
ALL DECIMAL ± .005" ANGULAR ± 1/2°	DRAWING BY: E.FORONDA	SCALE: 1.000	REVISION: B
THIRD-ANGLE	APP'D BY: AG	SHEETS: 1 of 1	
MATERIAL: 1097.00015.00	GAUGE: N/A	FINISH: N/A	