

# FETCO PN 1058.00026.00

REVISIONS					
SYM.	DESCRIPTION	DRFT.	CHK'D	APP.	DATE
A	RELEASED.	VR	BKS	SG	3/6/14
B	CHG. LED FROM 21009-009 TO -005, UPDATE NOTES, ECD 7309.	VR	BKS	Jt	3/25/14

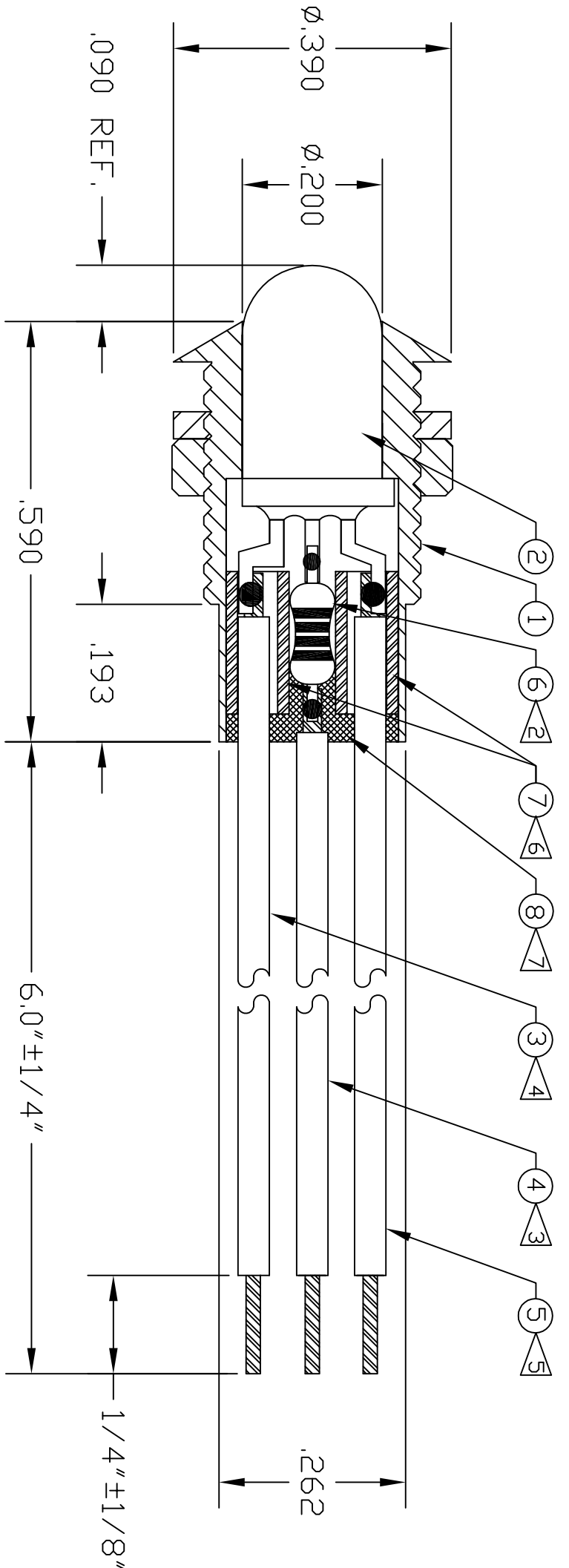

8. OPERATING VOLTAGE: 24 V, 20 mA.

7. SEAL WITH POTTING COMPOUND (P/N: 21048-000) (SPEC. ND. 800-024).
6. INSERT SLEEVES (P/N: 21138-004) OVER LED CATHODE LEADS.
5. SOLDER GREEN LEAD (P/N: 21358-035) TO LED GREEN CATHODE (SHORT LEAD).
4. SOLDER RED LEAD (P/N: 21359-059) TO LED RED CATHODE (FLAT SIDE).
3. SOLDER BLACK LEAD (P/N: 21325-011) TO RESISTOR (P/N: 21199-010).
2. SOLDER RESISTOR (P/N: 21199-010) TO LED COMMON ANODE (CENTER LEAD).
1. CUT INSIDE COMPONENT LEADS AS CLOSE AS POSSIBLE & STILL MAINTAIN GOOD JOINT STRENGTH.

NOTES:

1. 2. 3. 4.

UNIT TOOL #.	X	QTY.	ITEM	PART NUMBER	DESCRIPTION	MATL.
1	8	1	1	21048-000	POTTING COMPOUND	#0151
2	7	1	2	21138-004	PVC TUBING (.200)	BLACK
1	6	1	3	21199-010	.50 WATT METAL FILM RESISTOR	1050 OHMS
1	5	1	4	21358-035	24 AWG. WIRE, GREEN CATHODE	GREEN
1	4	1	5	21325-011	24 AWG. WIRE, COMMON ANODE	BLACK
1	3	1	6	21359-059	24 AWG. WIRE, RED CATHODE	RED
1	2	1	7	21009-005	T-1 3/4 BI-COLOR TRI-LEADED LED	RED/GREEN
1	1	1	8	21367-000	CC HOUSING (INCLUDES WASHER, NUT)	CHROME

DO NOT SCALE DRAWING. TOLERANCES UNLESS OTHERWISE SPECIFIED:  
 DECIMAL .xxxx = ALL DIMS. REFERENCED  
 FRACTION ±

THIS DRAWING OR SPECIFICATION IS THE EXCLUSIVE PROPERTY OF WILBRECHT LEDCO, INC. COPIES ARE ISSUED IN STRICT CONFIDENCE AND SHALL NOT BE REPRODUCED OR COPIED, OR DISCLOSED TO OTHERS, OR USED AS THE BASIS FOR THE MANUFACTURE OR SALE OF APPARATUS WITHOUT PERMISSION.

SCALE:	5:1	DATE	
DRAWN	V. Ronney	3/6/14	
CHECKED	SG	3/6/14	
PRD. ENG.	BKS	3/6/14	
APPROVED	Jt	3/25/14	
PROCESS NO.	X		

TITLE  
 CR SERIES  
**CC1-0905-9910 S**  
 6" LDS.

WILBRECHT LEDCO, INC.  
 ST. PAUL, MINNESOTA

78600-112  
 DWG. NO.

SHEET 1 OF 1

REV. B