

NOTES:

1. DRAWING TO BE INTERPRETED IN ACCORDANCE WITH THE CURRENT REVISION OF ASME Y14.5M.
2. TSI TO BE INTERPRETED AS THEORETICAL SHARP INTERSECTION
3. PARTS SHALL BE FREE OF ALL CONTAMINANTS INCLUDING GREASE, DIRT, MACHINING OIL AND OTHER CONTAMINANTS.
4. PARTS SHALL BE PACKAGED IN A MANNER TO PREVENT SCRATCHING, BOWING OR OTHER DAMAGE DURING SHIPMENT.
5. MISCELLANEOUS ADDED ITEMS, AS REQ'D.:
 - APPLY P/N 1022.00032.00 (SLEEVE),
 - P/N 1066.00002.00 (CABLE TIE, 20 PCS.),
 - P/N 1029.00005.00 (ADHESIVE TIE MOUNT, 10 PCS.),
 - P/N 1064.00005.00 (WIRE CONNECTOR, 3 PCS.),
 - P/N 1064.00004.00 (WIRE CONNECTOR, 1 PC.)
 - ALL PIECES ARE REQ'D. ON THE EMI FILTER WIRING AREA CONNECTIONS & ON THE HARNESS WIRING AREA AT ASSEMBLY.

REVISIONS				
REV	DATE	ECO NO	DESCRIPTION	BY:
A	01/26/2017	N/A	ORIGINAL	E. FORONDA

43	1	1064.00032.00	CRIMP CONN., PRE-INSULATED, NC-8
42	3	1064.00030.00	CRIMP CONNECTOR, PRE-INSULATED, 22-14 AWG WIRE RANGE
41	1	1043.00036.00	TEMPLATE, SN LABEL, FETCO PRODUCTS
40	1	1044.00013.00	LABEL EQUIPOTENTIALITY, CE
39	1	1065.00009.00	GROUND LUG CONNECTOR, 14-2 AWG, ALUMINUM
38	1	1401.00132.00	WIRING, GR-1 (L-N-PE), CE
37	1	1001.00020.00	COVER, REAR, GR-1/GRF-2
36	2	1081.00061.00	STANDOFF, 1/4 HEX x 1 1/4 LG., #6-32 THREAD
35	2	1083.00009.00	WASHER, #6 SCREW, INTL TOOTH LOCKWASHER
34	1	1052.00051.00	EMI FILTER, 10A, 120/250VAC, 50/60Hz
33	3	1084.00006.00	NUT, 8-32 18-8 HEX MACHINE SCREW
32	2	1083.00011.00	WASHER, #8 SCREW SIZE, INTERNAL TOOTH LOCK
31	2	1083.00016.00	WASHER, #8 SCREW SIZE, FLAT
30	1	1044.00012.00	LABEL GROUND, CE
29	1	1023.00041.00	HOLDER, BREW BASKET, GR-1/2
28	1	1028.00001.00	WINDOW, GR-1
27	1	1102.00023.00	COVER, GRINDER SERVICE ASSEMBLY, W/O RAILS
26	1	1058.00052.00	POWER SWITCH, DPST, 10A/250VAC, GREEN
25	2	1058.00007.00	SWITCH, START ROCKER, MOMENTARY, 250VAC
24	1	1045.00016.00	OVERLAY, GR-1.2
23	1	1084.00018.00	NUT, HEX, M8 SCREW SIZE
22	1	1083.00025.00	WASHER, M8 SCREW SIZE, SPRING LOCK
21	1	1067.00002.00	CAPACITOR, 230VAC VERSION, 12.5uF, 450VAC, 50-60Hz
20	2	1082.00023.00	SCREW, #8-32 X 3/8 TRUSS HD PHIL., MACHINE
19	2	1083.00010.00	WASHER, #10 SCREW W/NEOPRENE-BONDED SEAL
18	1	1023.00148.00	FUNNEL, HOPPER, GR-1
17	2	1082.00032.00	SCREW, 3/8"-16 X 3/4" LG, HEX HEAD CAP
16	2	1083.00020.00	WASHER, 3/8" SCREW SIZE, SPRING LOCK
15	2	1083.00022.00	WASHER, 3/8" SCREW SIZE, FLAT
14	1	1102.00185.00	GRINDING MOTOR AND PLATE ASSY, 230V/50Hz
13	1	1402.00096.00	HARNESS, GR-1/GR-2, CE VERSION ADDITION
12	8	1082.00033.00	SCREW, PAN HD PHIL. MACH., W/DUAL ACT WASHER, #6-32x3/8LG.
11	1	1046.00009.00	LABEL "GR PROGRAMMING"
10	1	1112.00023.00	BASE COVER WELDMENT, GR/GRF
9	1	1402.00010.00	ELECTRICAL HARNESS, GR 2.3
8	4	1029.00006.00	NUT, FINGER, #4-40 NYLON
7	1	1108.00029.00	ASSY. BOARD, CONTROL & SOFT. GR-1/2, 200-240VAC
6	4	1082.00031.00	SCREW, #10-32 X 5/8", PAN HD PHIL, MACHINE
5	4	1083.00019.00	WASHER, #10 SCREW SIZE, SPRING LOCK
4	4	1073.00006.00	FOOT, GRINDER
3	1	1082.00018.00	SCREW, TRUSS HD. PHIL. SM, #8 X 1/2 LG.
2	1	1021.00005.00	ROD, VIBRATION DAMPENING, GR-2
1	1	1111.00084.00	WELDMENT BODY, COMPLETE, GR-1, CE

ITEM NO	QTY	PART NO	DESCRIPTION
BILL OF MATERIALS			
TOLERANCES			
UNLESS OTHERWISE SPECIFIED			
ALL DIMENSIONS IN INCHES			
ALL DECIMAL ± .005"			
ANGULAR ± 1/2°			
THIRD-ANGLE			
MATERIAL N/A			
GAUGE N/A			
FINISH N/A			

FETCO FOOD EQUIPMENT TECHNOLOGIES COMPANY
 600 ROSE ROAD, LAKE ZURICH, IL 60047, USA
 PHONE: (800) 338-2699 FAX: (847) 719-3001
 E-MAIL: engineering@fetco.com www.fetco.com

DRAWING NAME: **GRINDER ASS'Y, GR-1.2, 230VAC, CE VERSION**

CREATED BY: E. FORONDA	DATE: 01/26/2017	DRAWING NO.:
DRAWING BY: E. FORONDA	SCALE: 0.125	1101.00338.00
APP'D BY: AG	SHEETS: 1 of 2	REVISION: A

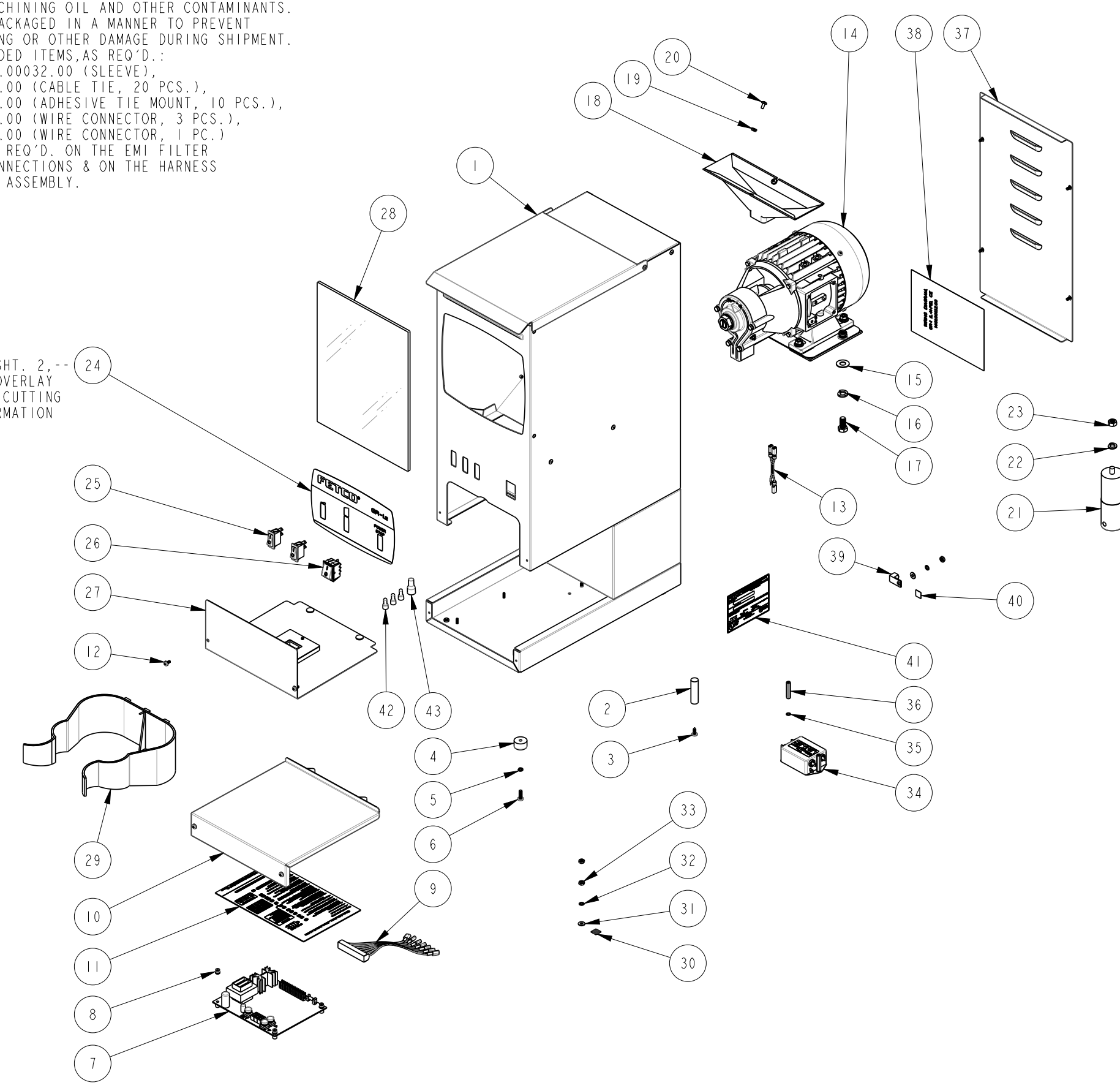

PROPRIETARY AND CONFIDENTIAL.
 THE INFORMATION CONTAINED IN THIS DRAWING IS THE SOLE PROPERTY OF FETCO.
 ANY REPRODUCTION IN PART OR AS A WHOLE WITHOUT THE WRITTEN PERMISSION OF FETCO IS PROHIBITED.

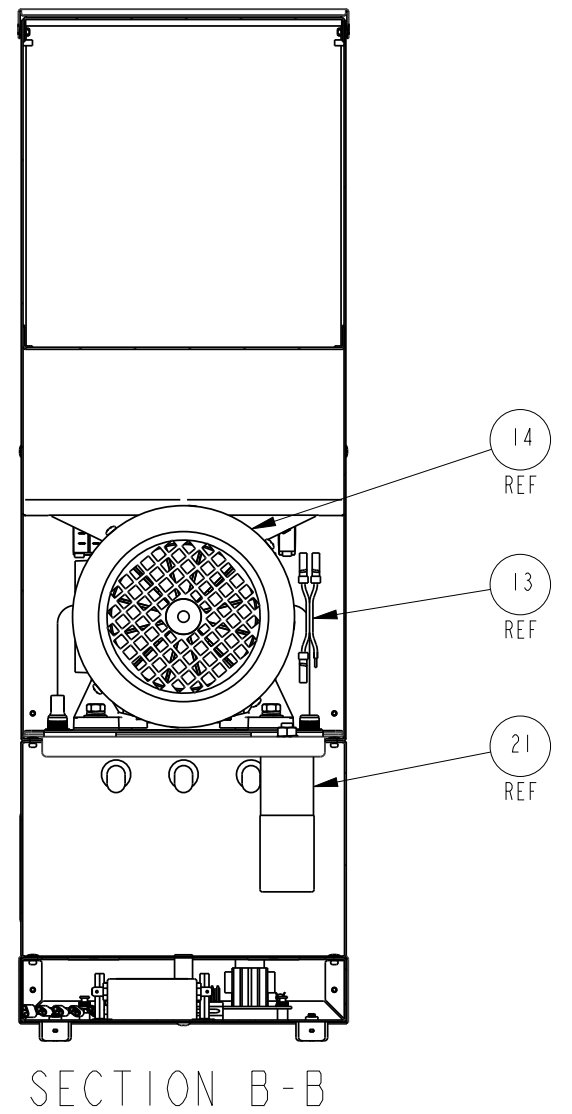
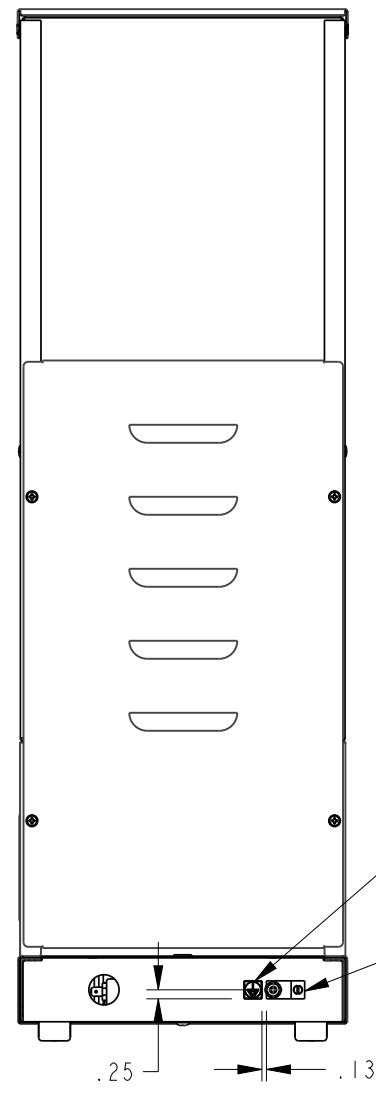
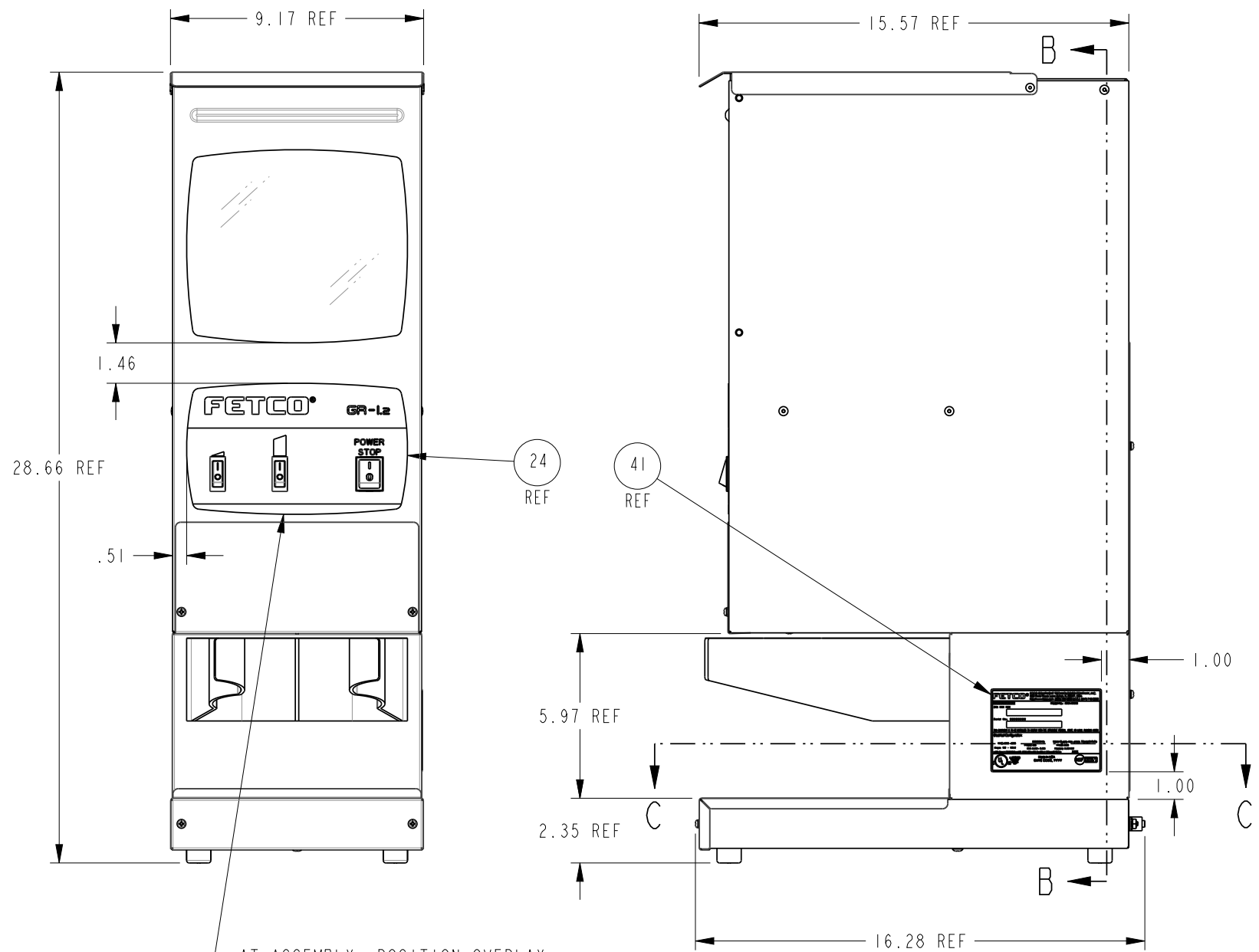
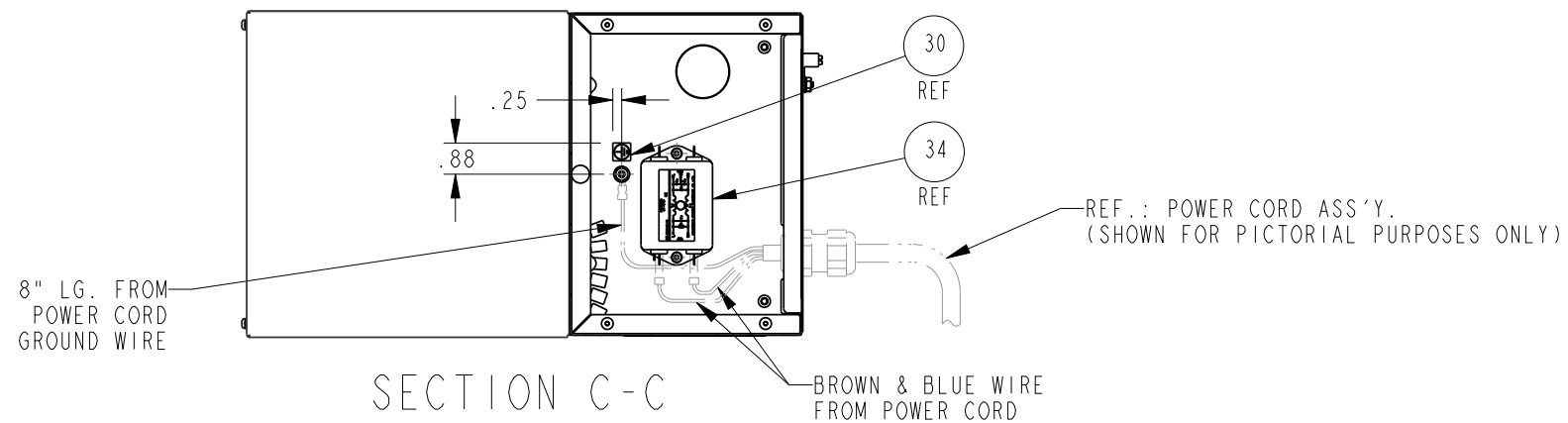

AT ASSEMBLY, POSITION OVERLAY AS SHOWN. ALIGN OVERLAY CUT-OUT OPENING HOLES, FROM THE SHEET METAL CUT-OUT HOLES AND ASSEMBLE SWITCHES AS SHOWN.

POSITION LABEL AS SHOWN

PROPRIETARY AND CONFIDENTIAL. THE INFORMATION CONTAINED IN THIS DRAWING IS THE SOLE PROPERTY OF FETCO. ANY REPRODUCTION IN PART OR AS A WHOLE WITHOUT THE WRITTEN PERMISSION OF FETCO IS PROHIBITED.

TOLERANCES			
UNLESS OTHERWISE SPECIFIED			
ALL DIMENSIONS IN INCHES			
ALL DECIMAL ± .005" ANGULAR ± 1/2°			
THIRD-ANGLE			
MATERIAL N/A			
GAUGE N/A			
FINISH N/A			
FETCO FOOD EQUIPMENT TECHNOLOGIES COMPANY 600 ROSE ROAD, LAKE ZURICH, IL 60047, USA PHONE: (800) 338-2699 FAX: (847) 719-3001 E-MAIL: engineering@fetco.com www.fetco.com		DRAWING NAME: GRINDER ASS'Y., GR-12, 230VAC, CE VERSION	
CREATED BY: E. FORONDA	DATE: 01/26/2017	DRAWING NO. 1101.00338.00	
DRAWING BY: E. FORONDA	SCALE: 0.188	REVISION A	
APP'D BY: AG	SHEETS: 2 of 2		