

NOTES:

1. DRAWING TO BE INTERPRETED IN ACCORDANCE WITH THE CURRENT REVISION OF ASME Y14.5M.
2. TSI TO BE INTERPRETED AS THEORETICAL SHARP INTERSECTION
3. PARTS SHALL BE FREE OF ALL CONTAMINANTS INCLUDING GREASE, DIRT, MACHINING OIL AND OTHER CONTAMINANTS.
4. PARTS SHALL BE PACKAGED IN A MANNER TO PREVENT SCRATCHING, BOWING OR OTHER DAMAGE DURING SHIPMENT.

ADDITIONAL PARTS REQUIRED BUT NOT PICTURED	
PART NUMBER	QUANTITY
1066.00002.00	16
1029.00005.00	9
1064.00004.00	1
1064.00005.00	3

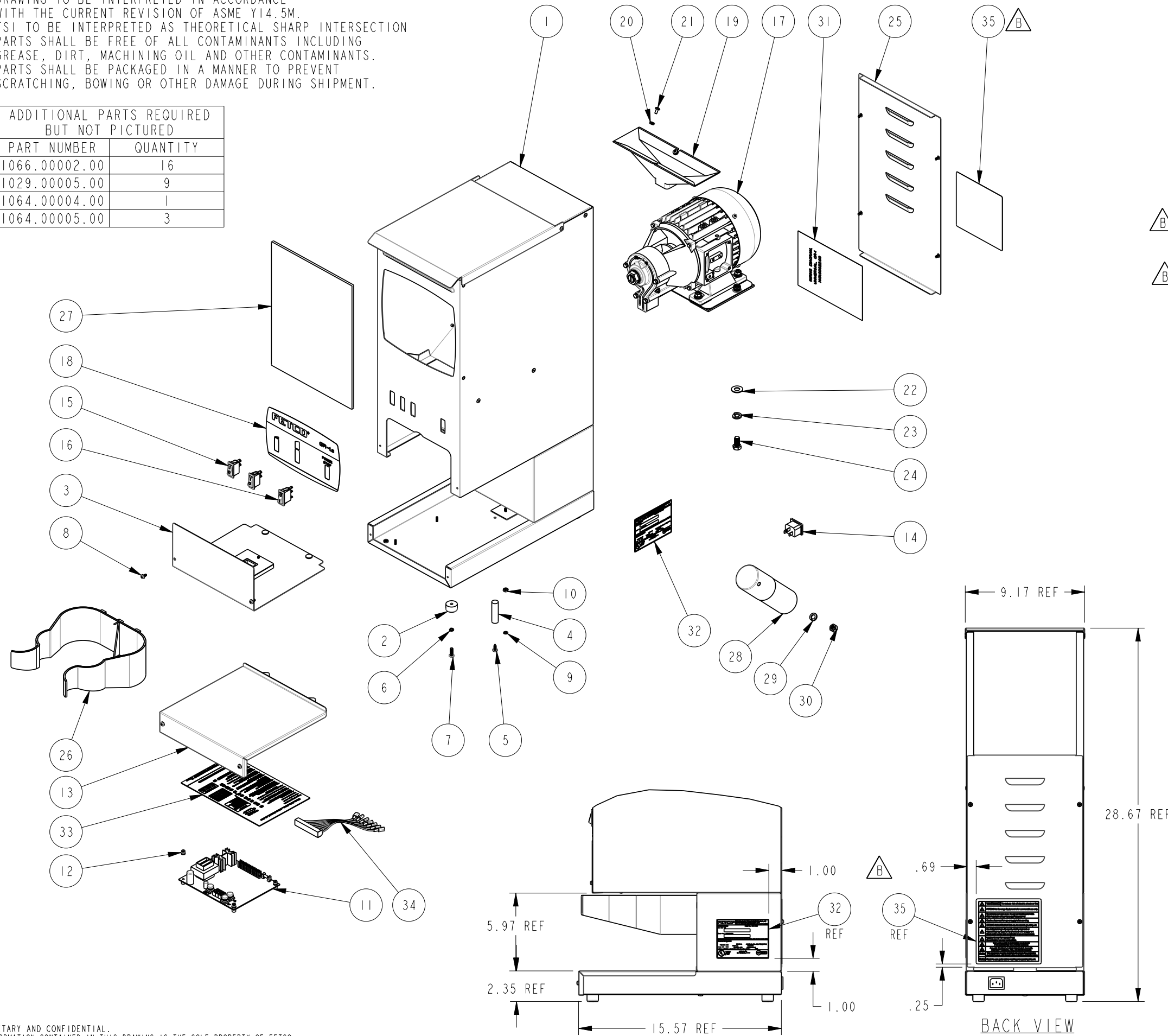

REVISIONS				
REV	DATE	ECO NO	DESCRIPTION	BY:
A	08/19/2015	N/A	ORIGINAL	DK
B	3/21/2017	N/A	ADDED ITEM 35, WARNING LABEL ITEM 32 WAS 1042.00004.00	E.FORONDA

35	1	1046.00035.00	LABEL, WARNING "TO REDUCE RISK OF ELECTRIC SHOCK OR FIRE"
34	1	1402.00010.00	ELECTRICAL HARNESS, GR 2.3
33	1	1046.00009.00	LABEL "GR PROGRAMMING"
32	1	1043.00036.00	TEMPLATE, SN LABEL, FETCO PRODUCTS
31	1	1401.00022.00	WIRING DIAGRAM, UNIVERSAL, GR-1
30	1	1084.00018.00	NUT, HEX, M8 SCREW SIZE
29	1	1083.00025.00	WASHER, M8 SCREW SIZE, SPRING LOCK
28	1	1067.00002.00	CAPACITOR, 230VAC VERSION, 12.5uF, 450VAC, 50-60Hz
27	1	1028.00001.00	WINDOW, GR-1
26	1	1023.00041.00	HOLDER, BREW BASKET, GR-1/2
25	1	1001.00020.00	COVER, REAR, GR-1/GRF-2
24	2	1082.00032.00	SCREW, 3/8"-16 X 3/4" LG, HEX HEAD CAP
23	2	1083.00020.00	WASHER, 3/8" SCREW SIZE, SPRING LOCK
22	2	1083.00022.00	WASHER, 3/8" SCREW SIZE, FLAT
21	2	1082.00023.00	SCREW, #8-32 X 3/8 TRUSS HD PHIL., MACHINE
20	2	1083.00010.00	WASHER, #10 SCREW W/NEOPRENE-BONDED SEAL
19	1	1023.00148.00	FUNNEL, HOPPER, GR-1
18	1	1045.00016.00	OVERLAY, GR-1.2
17	1	1102.00185.00	GRINDING MOTOR AND PLATE ASSY, 230V/50Hz
16	1	1058.00020.00	SWITCH, PWR ROCKER RED, ILLUM. 250VAC
15	2	1058.00007.00	SWITCH, START ROCKER, MOMENTARY, 250VAC
14	1	1065.00003.00	CONNECTOR, POWER INLET, 15A, 250VAC
13	1	1112.00023.00	BASE COVER WELDMENT, GR/GRF
12	4	1029.00006.00	NUT, FINGER, #4-40 NYLON
11	1	1108.00029.00	ASSY. BOARD, CONTROL & SOFT. GR-1/2, 200-240VAC
10	1	1084.00006.00	NUT, 8-32 18-8 HEX MACHINE SCREW
9	1	1083.00011.00	WASHER, #8 SCREW SIZE, INTERNAL TOOTH LOCK
8	8	1082.00033.00	SCREW, PAN HD PHIL. MACH., W/DUAL ACT WASHER, #6-32x3/8LG.
7	4	1082.00031.00	SCREW, #10-32 X 5/8", PAN HD PHIL, MACHINE
6	4	1083.00019.00	WASHER, #10 SCREW SIZE, SPRING LOCK
5	1	1082.00018.00	SCREW, TRUSS HD. PHIL. SM, #8 X 1/2 LG.
4	1	1021.00005.00	ROD, VIBRATION DAMPENING, GR-2
3	1	1102.00023.00	COVER, GRINDER SERVICE ASSEMBLY, W/O RAILS
2	4	1073.00006.00	FOOT, GRINDER
1	1	1111.00025.00	WELDMENT BODY, COMPLETE, GR-1

BILL OF MATERIALS			
ITEM NO	QTY	PART NO	DESCRIPTION
TOLERANCES			
UNLESS OTHERWISE SPECIFIED			
ALL DIMENSIONS IN INCHES			
ALL DECIMAL ± .005" ANGULAR ± 1/2°			
THIRD-ANGLE			
MATERIAL N/A			
GAUGE N/A			
FINISH N/A			

FETCO FOOD EQUIPMENT TECHNOLOGIES COMPANY
 600 ROSE ROAD, LAKE ZURICH, IL 60047, USA
 PHONE: (800) 338-2699 FAX: (847) 719-3001
 E-MAIL: engineering@fetco.com www.fetco.com

DRAWING NAME: ASSEMBLY, FINAL, GR-1.2, 230VAC, COMMON		
CREATED BY: DK	DATE 08/19/2015	DRAWING NO. 1101.00276.00
DRAWING BY: DK	SCALE 0.125	REVISION B
APP'D BY: AG	SHEETS 1 of 1	

PROPRIETARY AND CONFIDENTIAL.
 THE INFORMATION CONTAINED IN THIS DRAWING IS THE SOLE PROPERTY OF FETCO.
 ANY REPRODUCTION IN PART OR AS A WHOLE WITHOUT THE WRITTEN PERMISSION OF FETCO IS PROHIBITED.