

NOTES:

1. DRAWING TO BE INTERPRETED IN ACCORDANCE WITH THE CURRENT REVISION OF ASME Y14.5M.
2. TSI TO BE INTERPRETED AS THEORETICAL SHARP INTERSECTION
3. PARTS SHALL BE FREE OF ALL CONTAMINANTS INCLUDING GREASE, DIRT, MACHINING OIL AND OTHER CONTAMINANTS.
4. PARTS SHALL BE PACKAGED IN A MANNER TO PREVENT SCRATCHING, BOWING OR OTHER DAMAGE DURING SHIPMENT.

ADDITIONAL PARTS REQUIRED BUT NOT PICTURED

PART NUMBER	QUANTITY
1066.00002.00	20
1029.00005.00	10
1064.00005.00	3
1064.00004.00	1

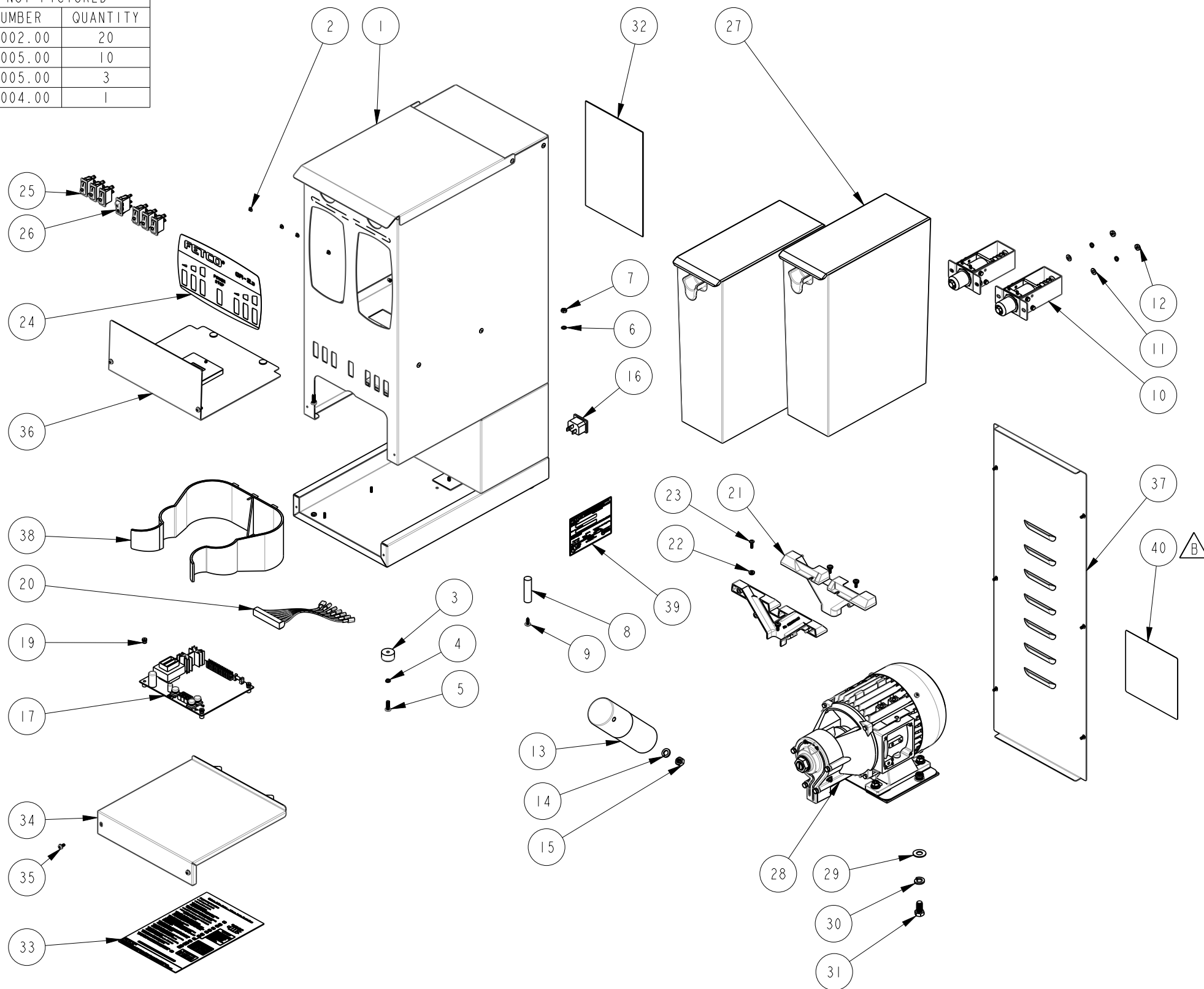

REVISIONS				
REV	DATE	ECO NO	DESCRIPTION	BY:
A	08/19/2015	N/A	ORIGINAL	DK
B	3/22/2017	N/A	ADDED ITEM 40, WARNING LABEL ITEM 39 WAS 1042.00004.00	E.FORONDA

ITEM NO	QTY	PART NO	DESCRIPTION
40	1	1046.00035.00	LABEL, WARNING "TO REDUCE RISK OF ELECTRIC SHOCK OR FIRE"
39	1	1043.00036.00	TEMPLATE, SN LABEL, FETCO PRODUCTS
38	1	1023.00041.00	HOLDER, BREW BASKET, GR-1/2
37	1	1001.00035.00	COVER, REAR, GR-2
36	1	1102.00023.00	COVER, GRINDER SERVICE ASSEMBLY, W/O RAILS
35	10	1082.00033.00	SCREW, PAN HD PHIL. MACH., W/DUAL ACT WASHER, #6-32x3/8LG.
34	1	1112.00023.00	BASE COVER WELDMENT, GR/GRF
33	1	1046.00009.00	LABEL "GR PROGRAMMING"
32	1	1401.00007.00	WIRING DIAGRAM, UNIVERSAL, GR-2
31	2	1082.00032.00	SCREW, 3/8"-16 X 3/4" LG, HEX HEAD CAP
30	2	1083.00020.00	WASHER, 3/8 SCREW SIZE, SPRING LOCK
29	2	1083.00022.00	WASHER, 3/8" SCREW SIZE, FLAT
28	1	1102.00185.00	GRINDING MOTOR AND PLATE ASSY, 230V/50Hz
27	2	1102.00033.00	HOPPER, ASSEMBLY, GRF-2.3
26	1	1058.00020.00	SWITCH, PWR ROCKER RED, ILLUM. 250VAC
25	6	1058.00007.00	SWITCH, START ROCKER, MOMENTARY, 250VAC
24	1	1045.00007.00	OVERLAY, GR-2.3
23	4	1082.00017.00	SCREW, TRUSS HD. PHIL. MACHINE, # 6-32 X 1/2 LG.
22	4	1083.00010.00	WASHER, #10 SCREW W/NEOPRENE-BONDED SEAL
21	2	1023.00044.00	MANIFOLD, GR-2
20	1	1402.00010.00	ELECTRICAL HARNESS, GR 2.3
19	4	1029.00006.00	NUT, FINGER, #4-40 NYLON
18	1	1050.00003.00	SOFTWARE, GRINDERS, V 1.2
17	1	1108.00029.00	ASSY. BOARD, CONTROL & SOFT. GR-1/2, 200-240VAC
16	1	1065.00003.00	CONNECTOR, POWER INLET, 15A, 250VAC
15	1	1084.00018.00	NUT, HEX, M8 SCREW SIZE
14	1	1083.00025.00	WASHER, M8 SCREW SIZE, SPRING LOCK
13	1	1067.00002.00	CAPACITOR, 230VAC VERSION, 12.5uF, 450VAC, 50-60Hz
12	4	1084.00014.00	NUT, HEX, #10-32, MACHINE SCREW
11	4	1083.00026.00	WASHER, #10 SCREW SIZE, FLAT
10	2	1102.00304.00	SOLENOID ASSEMBLY, 230VAC, GR-2
9	1	1082.00018.00	SCREW, TRUSS HD. PHIL. SM, #8 X 1/2 LG.
8	1	1021.00005.00	ROD, VIBRATION DAMPENING, GR-2
7	1	1084.00006.00	NUT, 8-32 18-8 HEX MACHINE SCREW
6	1	1083.00011.00	WASHER, #8 SCREW SIZE, INTERNAL TOOTH LOCK
5	4	1082.00031.00	SCREW, #10-32 X 5/8", PAN HD PHIL, MACHINE
4	8	1083.00019.00	WASHER, #10 SCREW SIZE, SPRING LOCK
3	4	1073.00006.00	FOOT, GRINDER
2	4	1029.00009.00	FASTENER, 9/32" HEAD DIA X .165" LG, PUSH IN
1	1	1111.00011.00	BODY, WELDMENT, GR-2

BILL OF MATERIALS			
TOLERANCES			
UNLESS OTHERWISE SPECIFIED			
ALL DIMENSIONS IN INCHES			
ALL DECIMAL ± .005"			
ANGULAR ± 1/2°			
THIRD-ANGLE			
MATERIAL N/A			
GAUGE N/A			
FINISH N/A			
DRAWING NAME:		DRAWING NO.	
<b>GRINDER ASSEMBLY, GR-2.3, 230VAC, COMMON</b>		<b>1101.00275.00</b>	
CREATED BY:	DATE	DRAWING NO.	
DK	08/19/2015	1101.00275.00	
DRAWING BY:	SCALE	REVISION	
DK	0.125	<b>B</b>	
APP'D BY:	SHEETS	REVISION	
AG	1 of 2	<b>B</b>	
MATERIAL		GAUGE	FINISH
N/A		N/A	N/A

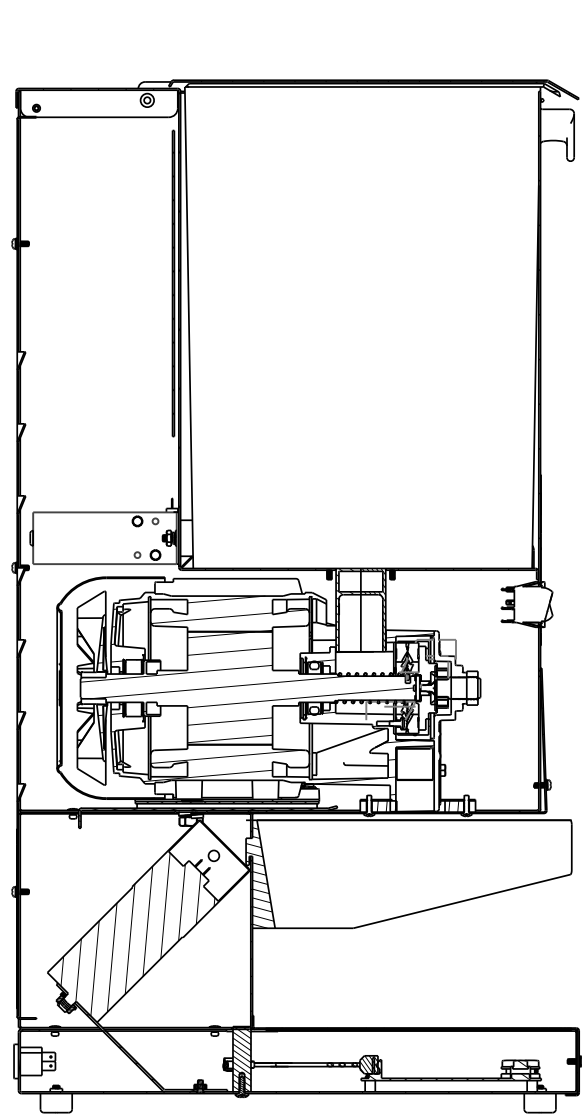

SECTION A-A

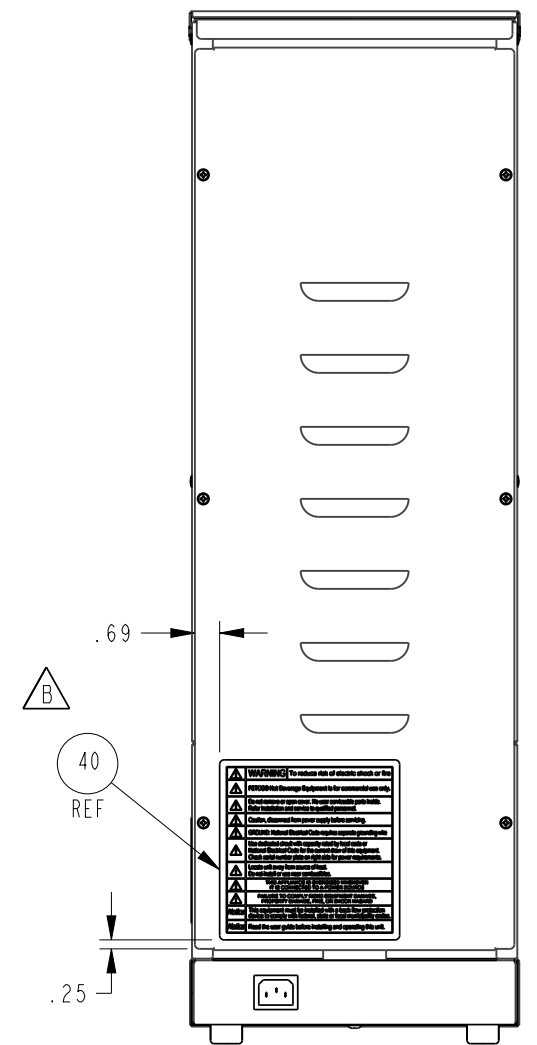
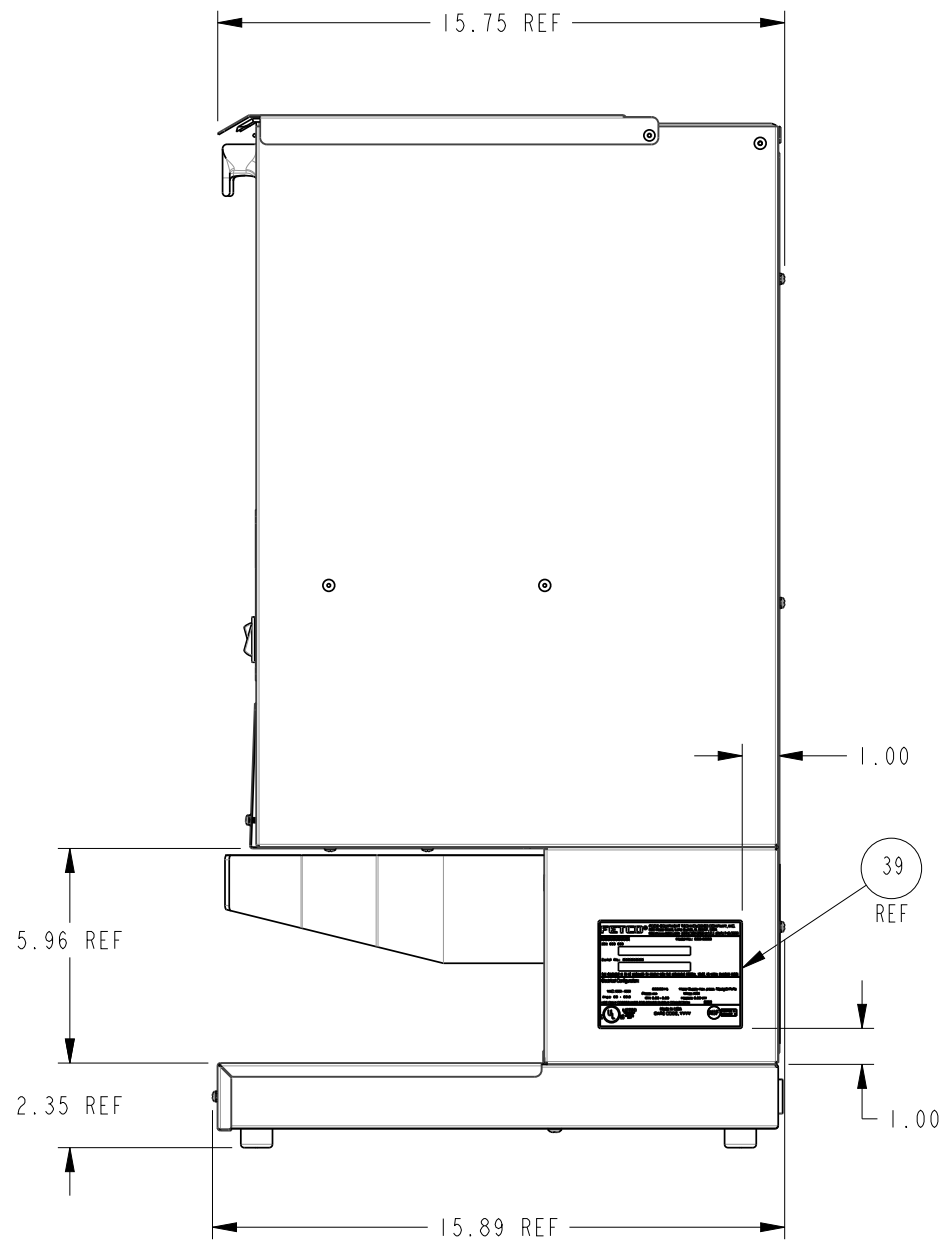
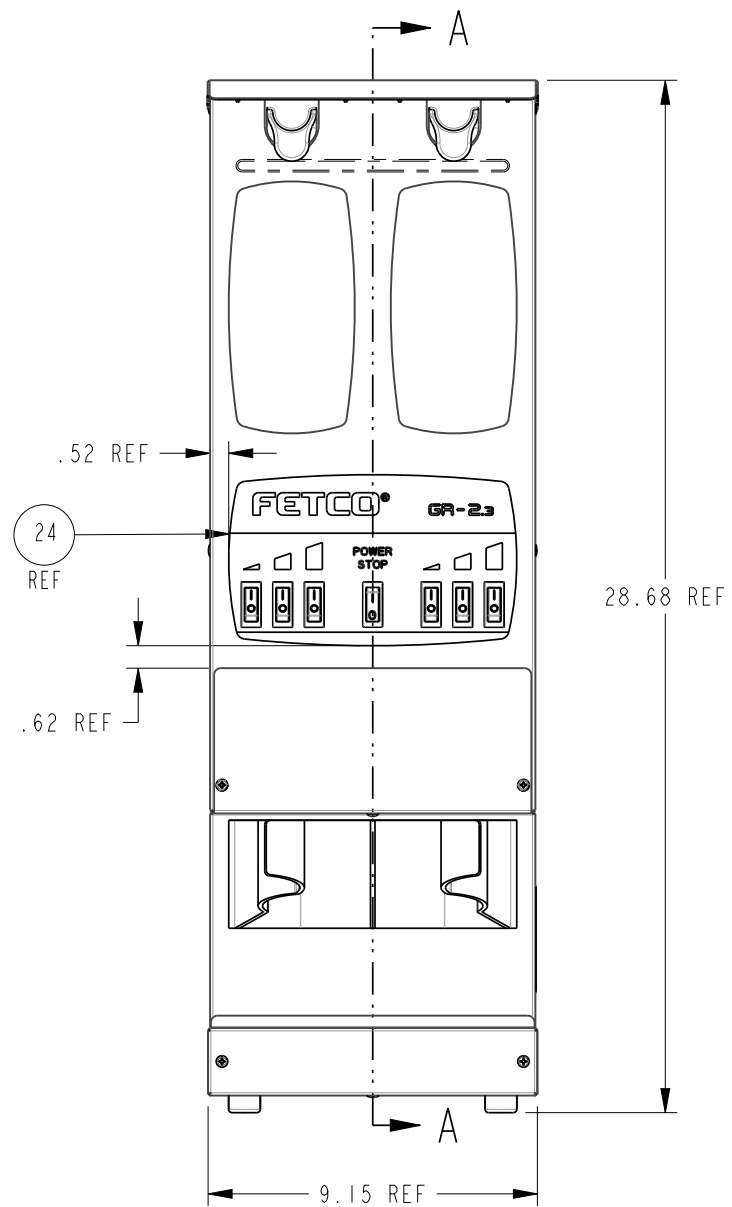

PROPRIETARY AND CONFIDENTIAL.  
 THE INFORMATION CONTAINED IN THIS DRAWING IS THE SOLE PROPERTY OF FETCO.  
 ANY REPRODUCTION IN PART OR AS A WHOLE WITHOUT THE WRITTEN PERMISSION OF FETCO IS PROHIBITED.

TOLERANCES UNLESS OTHERWISE SPECIFIED		<b>FETCO</b> FOOD EQUIPMENT TECHNOLOGIES COMPANY 600 ROSE ROAD, LAKE ZURICH, IL 60047, USA PHONE: (800) 338-2699 FAX: (847) 719-3001 E-MAIL: engineering@fetco.com www.fetco.com	
ALL DIMENSIONS IN INCHES		DRAWING NAME: <b>GRINDER ASSEMBLY, GR-2.3, 230VAC, COMMON</b>	
ALL DECIMAL ± .005" ANGULAR ± 1/2°	THIRD-ANGLE	CREATED BY: DK	DATE 08/19/2015
		DRAWING BY: DK	SCALE 0.188
		APP'D BY: AG	SHEETS 2 of 2
MATERIAL N/A	GAUGE N/A	DRAWING NO. <b>1101.00275.00</b>	
		REVISION <b>B</b>	
		FINISH N/A	