

 <b>FOOD EQUIPMENT TECHNOLOGIES INC.</b> 600 ROSE AVENUE LAKE ZURICH, IL 60047-1560 PHONE (847) 719-3220 EMAIL: <a href="mailto:engineering@fetco.com">engineering@fetco.com</a> <a href="http://www.fetco.com">www.fetco.com</a>		
Title CBS21xx Fixture		
Author Peter Hedlund FETCO R&D		
File CBS21xx_Fixture\Docs\cbs21xx_auto_fixture.dsn		Document
Revision 1.2	Date 01/24/2017	Sheets 1 of 1

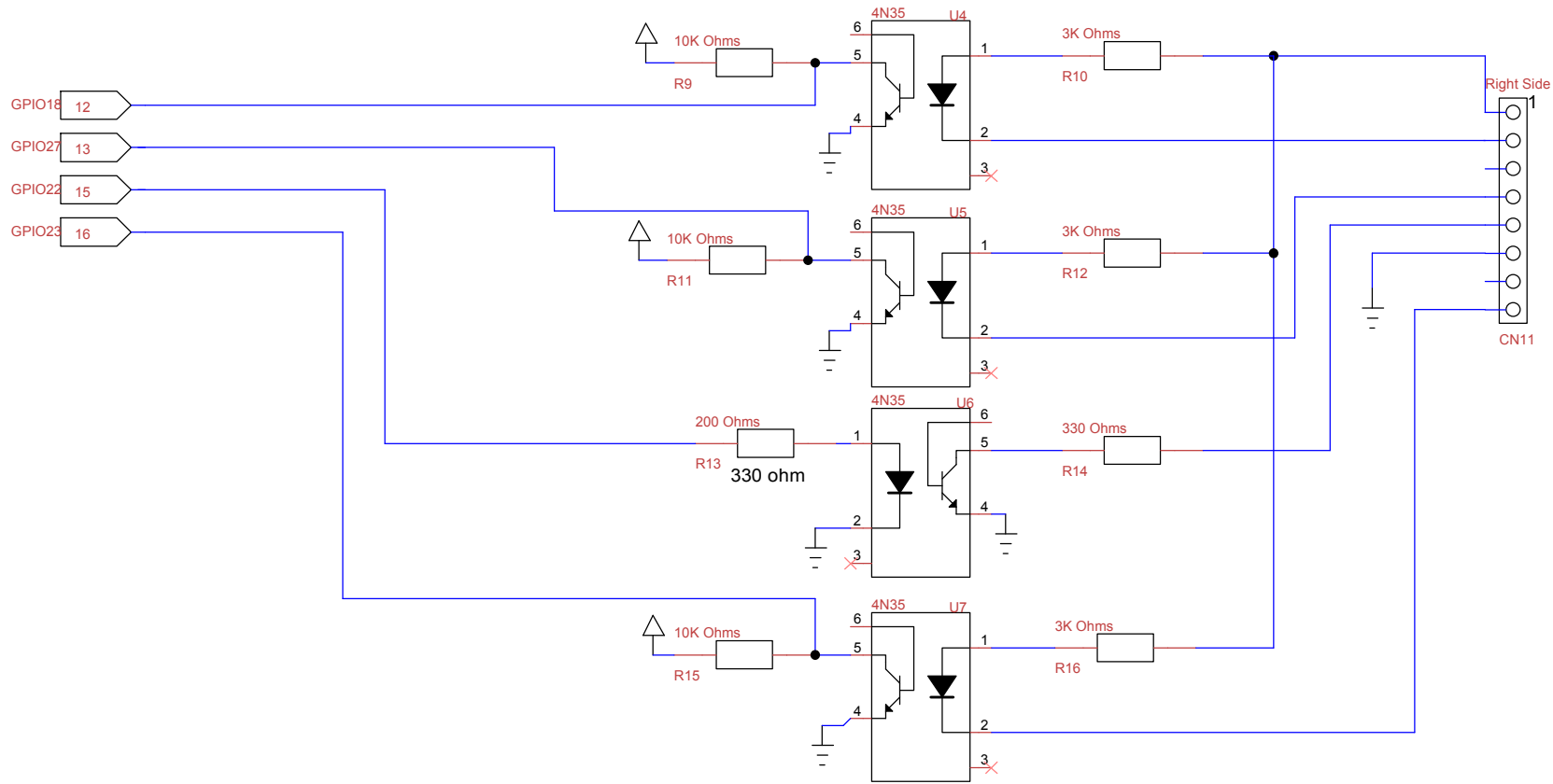

<b>FETCO</b>		FOOD EQUIPMENT TECHNOLOGIES INC. 600 ROSE AVENUE, LAKE ZURICH, IL 60047-1560 PHONE (847) 719-3220 EMAIL: <a href="mailto:engineering@fetco.com">engineering@fetco.com</a> <a href="http://www.fetco.com">www.fetco.com</a>	
Title CBS21xx Fixture			
Author Peter Hedlund FETCO R&D			
File CBS21xx_Fixture\Docs\cbs21xx_auto_fixture.dsn		Document	
Revision 1.2	Date 01/24/2017	Sheets 2	

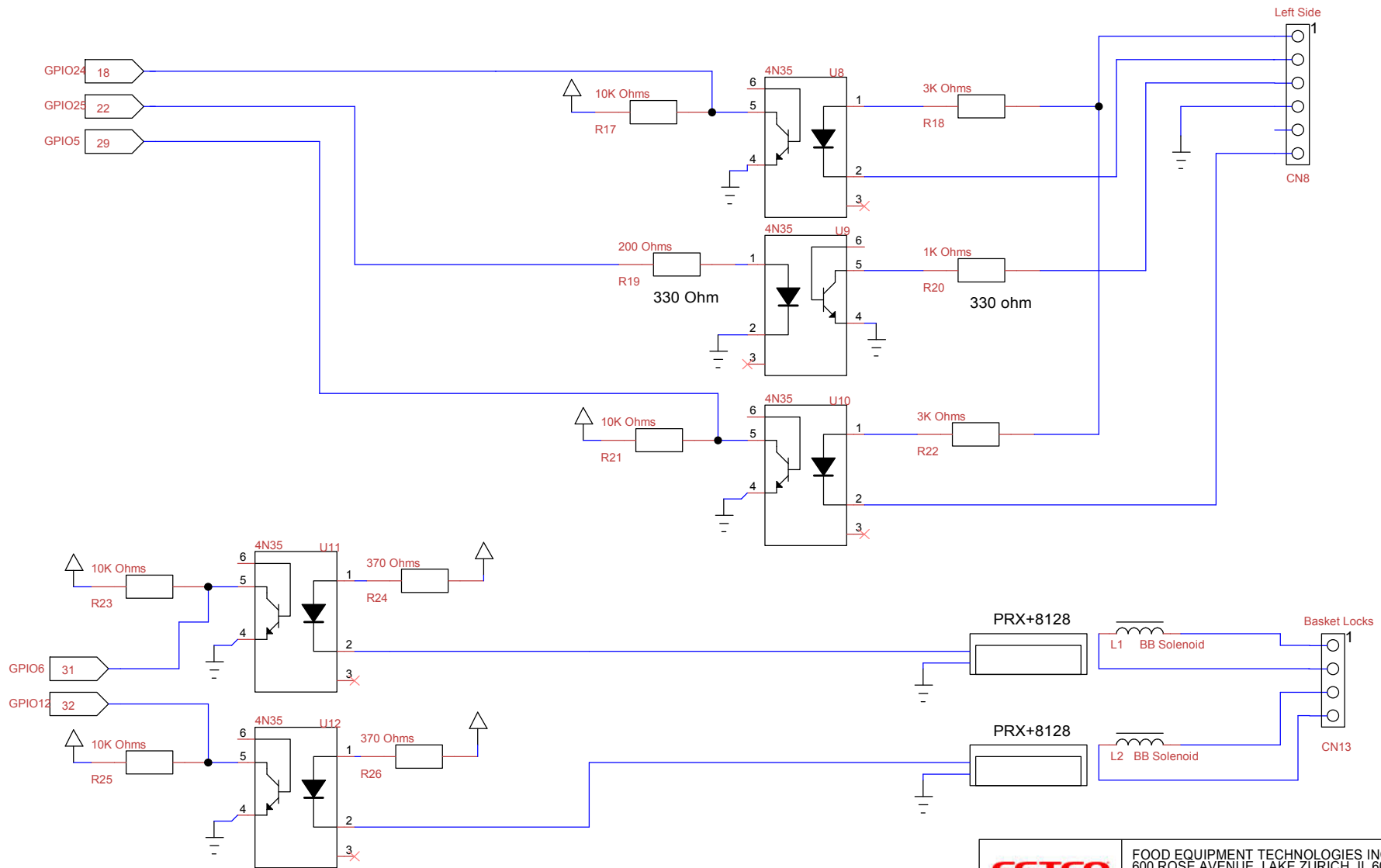

<b>FETCO</b>		
FOOD EQUIPMENT TECHNOLOGIES INC. 600 ROSE AVENUE, LAKE ZURICH, IL 60047-1560 PHONE (847) 719-3220 EMAIL: <a href="mailto:engineering@fetco.com">engineering@fetco.com</a> <a href="http://www.fetco.com">www.fetco.com</a>		
Title CBS21xx Fixture		
Author Peter Hedlund FETCO R&D		
File CBS21xx_Fixture\Docs\cbs21xx_auto_fixture.dsn		Document
Revision 1.2	Date 01/24/2017	Sheets 3