

NOTES:

1. CHANGE OF MATERIAL IS NOT PERMITTED UNLESS APPROVED IN WRITING BY FETCO PERSONNEL.
2. DRAWING TO BE INTERPRETED IN ACCORDANCE WITH THE CURRENT REVISION OF ASME Y14.5M.
3. TSI TO BE INTERPRETED AS THEORETICAL SHARP INTERSECTION.
4. PARTS SHALL BE FREE OF ALL CONTAMINANTS INCLUDING GREASE, DIRT, MACHINING OIL AND OTHER CONTAMINANTS.
5. PARTS SHALL BE PACKAGED IN A MANNER TO PREVENT SCRATCHING, BOWING OR OTHER DAMAGE DURING SHIPMENT.
6. PURCHASED FROM: LC ELECTRONIK  
VENDOR P/N: LCKLI086-51

REVISIONS				
REV	DATE	ECO NO	DESCRIPTION	BY:
A	06/10/2015	N/A	ORIGINAL	DK

**A**

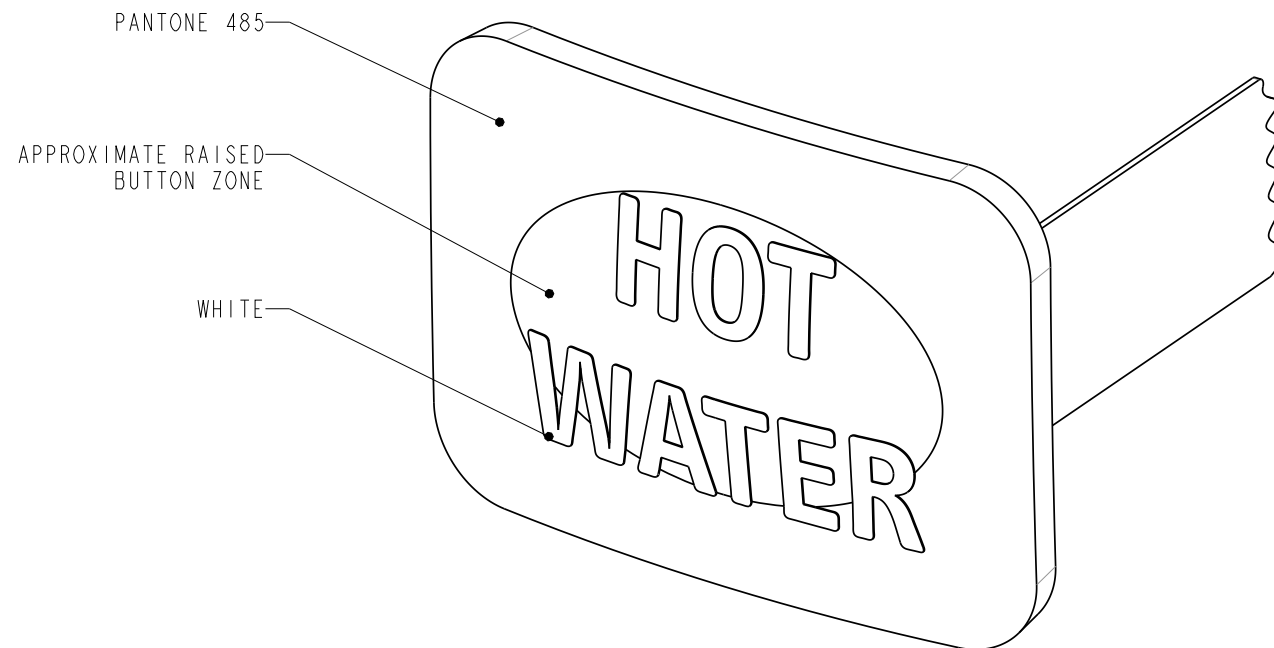

SCALE 4.000

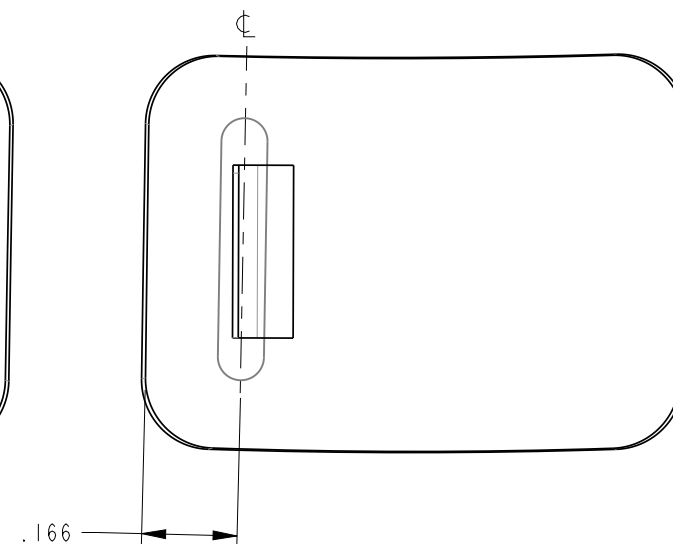
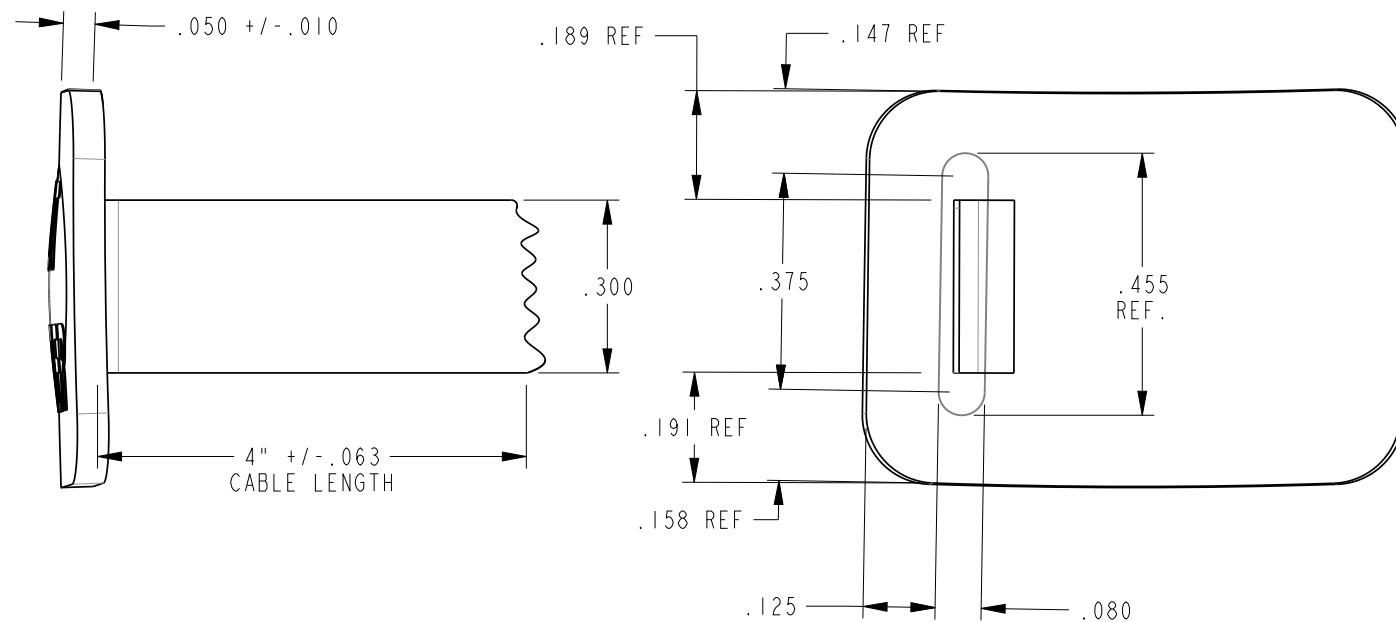
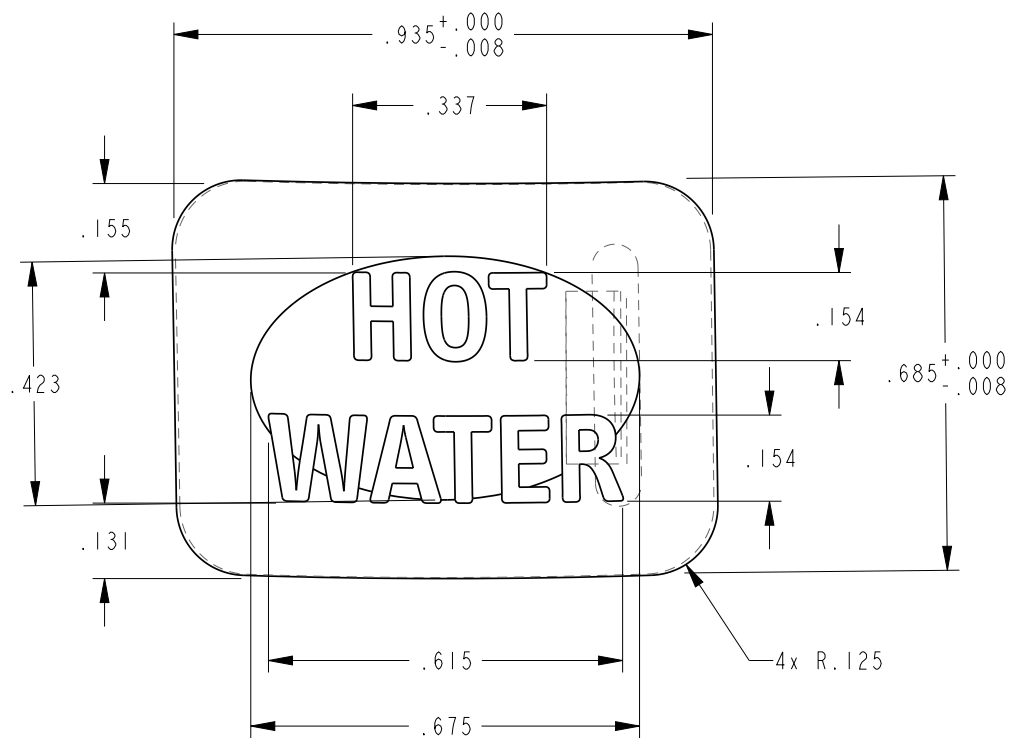

PROPRIETARY AND CONFIDENTIAL.  
THE INFORMATION CONTAINED IN THIS DRAWING IS THE SOLE PROPERTY OF FETCO.  
ANY REPRODUCTION IN PART OR AS A WHOLE WITHOUT THE WRITTEN PERMISSION OF FETCO IS PROHIBITED.

TOLERANCES		<b>FETCO</b> FOOD EQUIPMENT TECHNOLOGIES COMPANY	
UNLESS OTHERWISE SPECIFIED		600 ROSE ROAD, LAKE ZURICH, IL 60047, USA PHONE: (800) 338-2699 FAX: (847) 719-3001 E-MAIL: engineering@fetco.com www.fetco.com	
ALL DIMENSIONS IN INCHES		DRAWING NAME: <b>MEMBRANE SWITCH, HOT WATER</b>	
ALL DECIMAL ± .005" ANGULAR ± 1/2°	THIRD-ANGLE	CREATED BY: DK	DATE 06/10/2015
		DRAWING BY: DK	SCALE 3.000
		APP'D BY: SP	SHEETS 1 of 1
MATERIAL SEE NOTE 6	GAUGE N/A	DRAWING NO. <b>1058.00043.00</b>	
		REVISION <b>A</b>	
		FINISH N/A	