

NOTES:

1. DRAWING TO BE INTERPRETED IN ACCORDANCE WITH THE CURRENT REVISION OF ASME Y14.5M.
2. TSI TO BE INTERPRETED AS THEORETICAL SHARP INTERSECTION
3. PARTS SHALL BE FREE OF ALL CONTAMINANTS INCLUDING GREASE, DIRT, MACHINING OIL AND OTHER CONTAMINANTS.
4. PARTS SHALL BE PACKAGED IN A MANNER TO PREVENT SCRATCHING, BOWING OR OTHER DAMAGE DURING SHIPMENT.

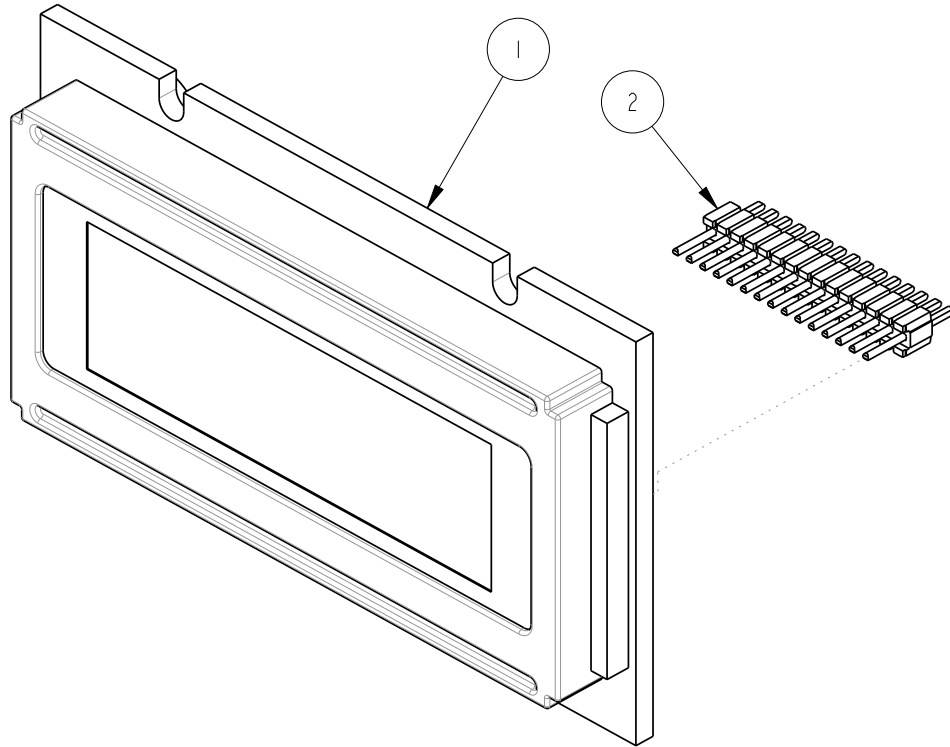

REVISIONS				
REV	DATE	ECO NO	DESCRIPTION	BY:
A	8/16/2017	N/A	ORIGINAL	E.FORONDA

A

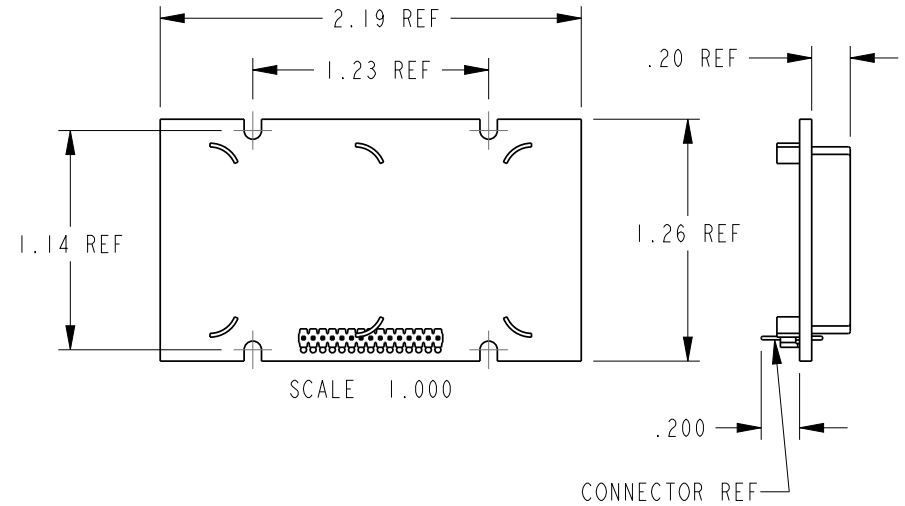

DRAWING IS FOR QUOTING PURPOSES ONLY

2	1	1065.00012.00	CONNECTOR, DISPLAY
1	1	1058.00050.00	DISPLAY, LCD, 12x2 CHARACTERS, WHITE ON BLACK
ITEM NO	QTY	PART NO	DESCRIPTION

BILL OF MATERIALS

TOLERANCES UNLESS OTHERWISE SPECIFIED		FETCO FOOD EQUIPMENT TECHNOLOGIES COMPANY 600 ROSE ROAD, LAKE ZURICH, IL 60047, USA PHONE: (800) 338-2699 FAX: (847) 719-3001 E-MAIL: engineering@fetco.com www.fetco.com	
ALL DIMENSIONS IN INCHES		DRAWING NAME: DISPLAY, LCD, 12x2 CHARACTERS WITH CONNECTOR	
ALL DECIMAL ± .005" ANGULAR ± 1/2°		CREATED BY: E.FORONDA	DATE 8/16/2017
THIRD-ANGLE		DRAWING BY: E.FORONDA	SCALE 2.000
		APP'D BY: RH	SHEETS 1 of 1
MATERIAL N/A		GAUGE N/A	FINISH N/A
		DRAWING NO 1102.00384.00	
		REVISION A	