

NOTES:

1. DRAWING TO BE INTERPRETED IN ACCORDANCE WITH THE CURRENT REVISION OF ASME Y14.5M.
2. TSI TO BE INTERPRETED AS THEORETICAL SHARP INTERSECTION
3. PARTS SHALL BE FREE OF ALL CONTAMINANTS INCLUDING GREASE, DIRT, MACHINING OIL AND OTHER CONTAMINANTS.
4. PARTS SHALL BE PACKAGED IN A MANNER TO PREVENT SCRATCHING, BOWING OR OTHER DAMAGE DURING SHIPMENT.

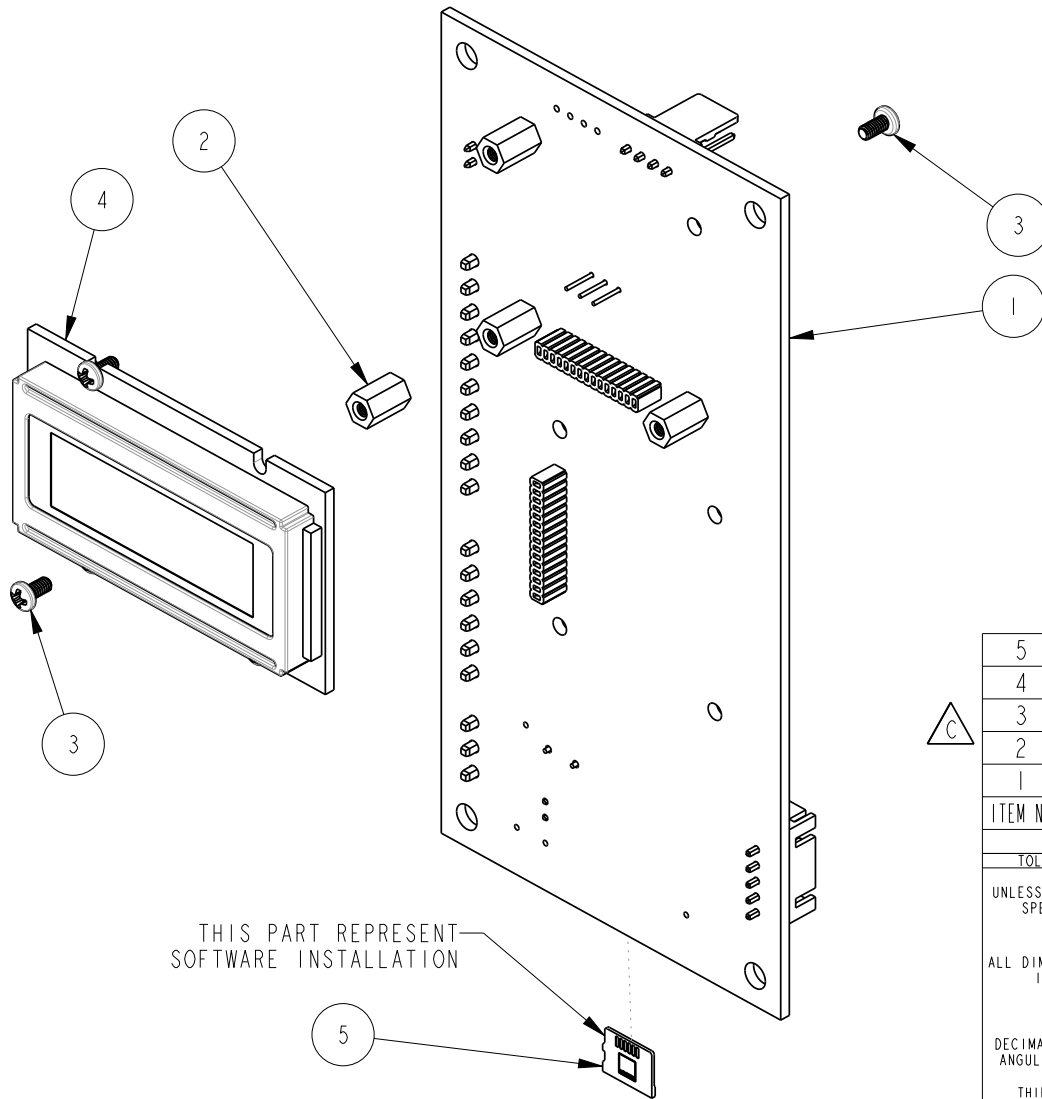

THIS PART REPRESENT SOFTWARE INSTALLATION

REVISIONS				
REV	DATE	ECO NO	DESCRIPTION	BY:
A	08/23/2016	N/A	ORIGINAL	DK
B	8/17/2017	N/A	REMOVED ITEM 1065.00012.00	E.FORONDA
C	10/16/2017	N/A	CHANGED ITEM 2, WAS 1081.00065.00 ITEM 1082.00124.00 WAS 1082.00119.00	E.FORONDA

C

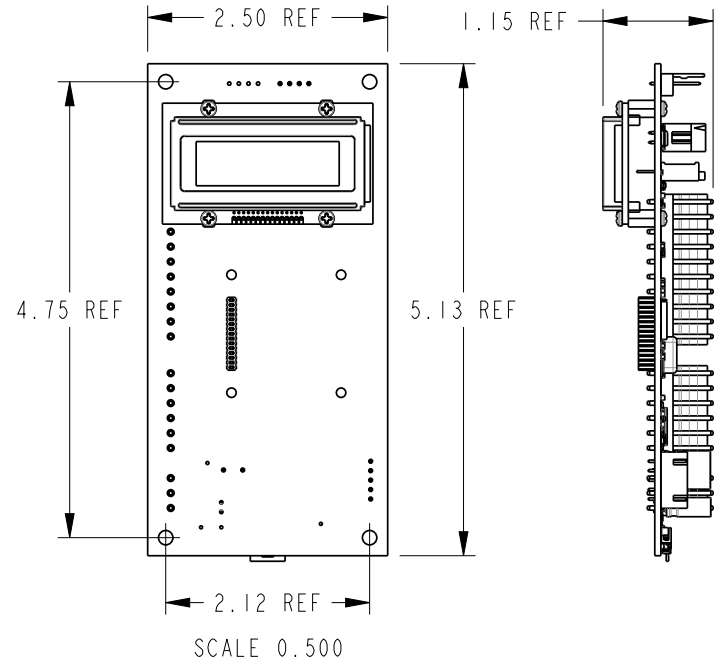

5	1	1108.00036.00	SOFTWARE INSTALLATION, CBS-1100
4	1	1102.00384.00	DISPLAY, LCD, 12x2 CHARACTERS WITH CONNECTOR
3	8	1082.00124.00	SCREW, RND. HD. PHILLIPS MACH., #2-56x5/32" LG. THRD.
2	4	1081.00068.00	STANDOFF, NYLON 6/6, 3/16 HEX x 9/32 LG., #2-56 FEM THRD
1	1	1051.00041.00	CONTROL BOARD, CBS-1100, 24VDC

ITEM NO	QTY	PART NO	DESCRIPTION
---------	-----	---------	-------------

BILL OF MATERIALS

TOLERANCES UNLESS OTHERWISE SPECIFIED	FETCO FOOD EQUIPMENT TECHNOLOGIES COMPANY 600 ROSE ROAD, LAKE ZURICH, IL 60047, USA PHONE: (800) 338-2699 FAX: (847) 719-3001 E-MAIL: engineering@fetco.com www.fetco.com		
	DRAWING NAME: ASSEMBLY, CONTROL BOARD, CBS-1100		
ALL DIMENSIONS IN INCHES	CREATED BY: DK	DATE 08/23/2016	DRAWING NO 1102.00371.00
	DRAWING BY: E.FORONDA	SCALE 1.000	REVISION C
ALL DECIMAL ± .005" ANGULAR ± 1/2°	APP'D BY: AG	SHEETS 1 of 1	
THIRD-ANGLE	MATERIAL N/A	GAUGE N/A	FINISH N/A