

NOTES:

1. DRAWING TO BE INTERPRETED IN ACCORDANCE WITH THE CURRENT REVISION OF ASME Y14.5M.
2. TSI TO BE INTERPRETED AS THEORETICAL SHARP INTERSECTION
3. PARTS SHALL BE FREE OF ALL CONTAMINANTS INCLUDING GREASE, DIRT, MACHINING OIL AND OTHER CONTAMINANTS.
4. PARTS SHALL BE PACKAGED IN A MANNER TO PREVENT SCRATCHING, BOWING OR OTHER DAMAGE DURING SHIPMENT.
5. BOX INSERTS, USE PART No.'S. 1098.00147.00, 1098.00148.00 & 1098.00149.00
6. USER GUIDE, USE PART No. P167
7. SHIPPING BOX, USE PART No. 1098.00118.00

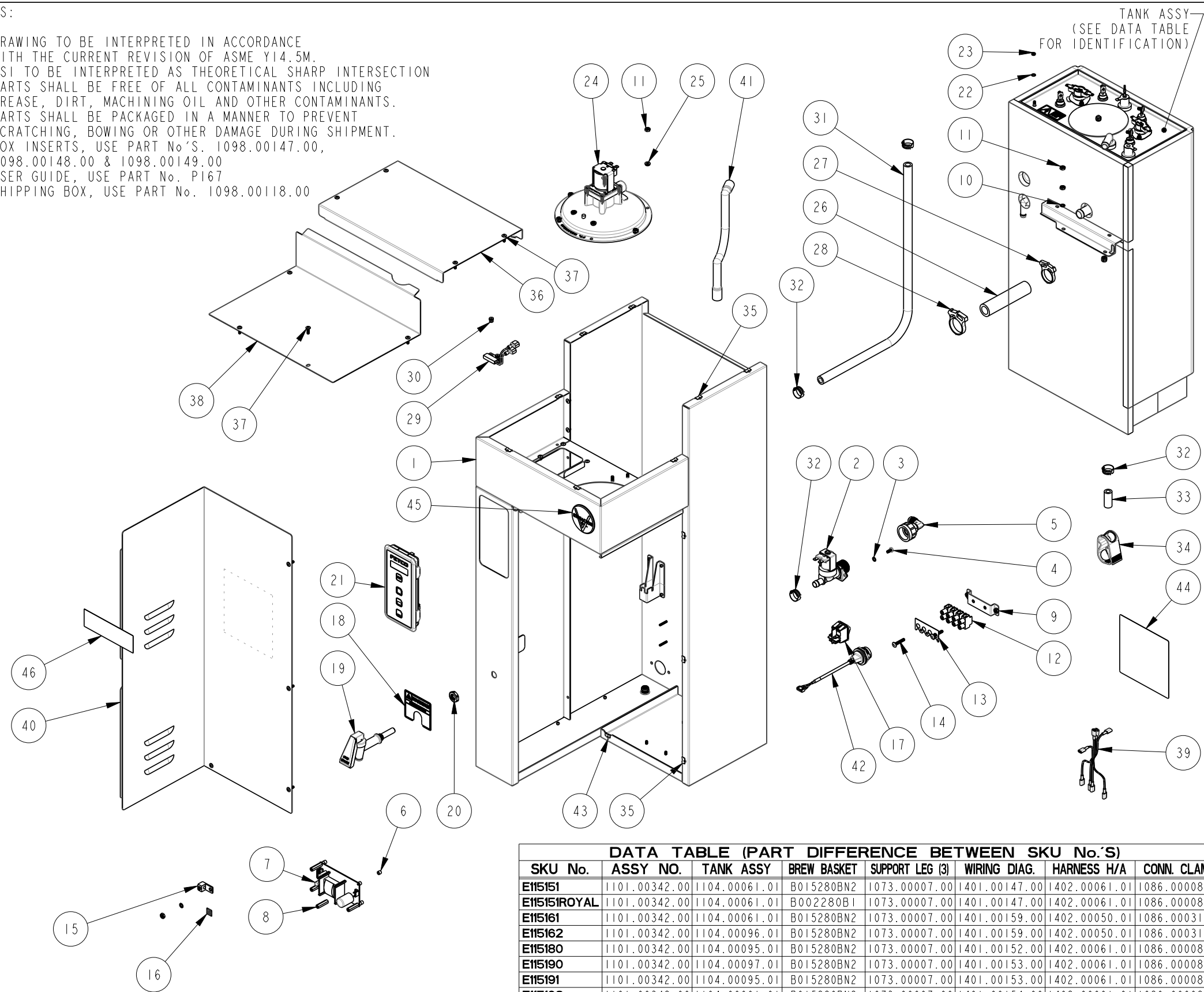

DATA TABLE (PART DIFFERENCE BETWEEN SKU No.'S)							
SKU No.	ASSY NO.	TANK ASSY	BREW BASKET	SUPPORT LEG (3)	WIRING DIAG.	HARNESS H/A	CONN. CLAMP
E115151	1101.00342.00	1104.00061.01	B015280B2	1073.00007.00	1401.00147.00	1402.00061.01	1086.00008.00
E115151ROYAL	1101.00342.00	1104.00061.01	B002280B1	1073.00007.00	1401.00147.00	1402.00061.01	1086.00008.00
E115161	1101.00342.00	1104.00061.01	B015280B2	1073.00007.00	1401.00159.00	1402.00050.01	1086.00031.00
E115162	1101.00342.00	1104.00096.01	B015280B2	1073.00007.00	1401.00159.00	1402.00050.01	1086.00031.00
E115180	1101.00342.00	1104.00095.01	B015280B2	1073.00007.00	1401.00152.00	1402.00061.01	1086.00008.00
E115190	1101.00342.00	1104.00097.01	B015280B2	1073.00007.00	1401.00153.00	1402.00061.01	1086.00008.00
E115191	1101.00342.00	1104.00095.01	B015280B2	1073.00007.00	1401.00153.00	1402.00061.01	1086.00008.00
E115192	1101.00342.00	1104.00061.01	B015280B2	1073.00007.00	1401.00154.00	1402.00061.01	1086.00008.00
E115193	1101.00342.00	1104.00096.01	B015280B2	1073.00007.00	1401.00154.00	1402.00061.01	1086.00008.00
E115151M	1101.00342.00	1104.00061.01	B001280B1	1073.00007.00	1401.00147.00	1402.00061.01	1086.00008.00
E115161M	1101.00342.00	1104.00061.01	B001280B1	1073.00007.00	1401.00159.00	1402.00050.01	1086.00031.00
E115162M	1101.00342.00	1104.00096.01	B001280B1	1073.00007.00	1401.00159.00	1402.00050.01	1086.00031.00
E115180M	1101.00342.00	1104.00095.01	B001280B1	1073.00007.00	1401.00152.00	1402.00061.01	1086.00008.00
E115190M	1101.00342.00	1104.00097.01	B001280B1	1073.00007.00	1401.00153.00	1402.00061.01	1086.00008.00
E115191M	1101.00342.00	1104.00095.01	B001280B1	1073.00007.00	1401.00153.00	1402.00061.01	1086.00008.00
E115192M	1101.00342.00	1104.00061.01	B001280B1	1073.00007.00	1401.00154.00	1402.00061.01	1086.00008.00
E115193M	1101.00342.00	1104.00096.01	B001280B1	1073.00007.00	1401.00154.00	1402.00061.01	1086.00008.00

REVISIONS				
REV	DATE	ECO NO	DESCRIPTION	BY:
A	07/18/2016	N/A	ORIGINAL	DK

46	1	1046.00003.00	LABEL, CSD WARNING, 1.5" X 5.0"
45	1	1041.00031.00	LABEL, EXTRACTOR V+ LOGO
44	1	1046.00035.00	LABEL, WARNING "TO REDUCE RISK OF ELECTRIC SHOCK OR FIRE"
43	1	1084.00024.00	NUT, CLIP ON (J-NUT), #6-32, 1050 SPR. STL.
42	1	1058.00055.00	USB CONNECTOR
41	1	1024.00098.00	VENT TUBE, XTS AND I1XX
40	1	1112.00470.00	WELDMENT, RIGHT COVER, CBS-1150 XV+
39	1	1402.00097.01	HARNESS, LOW AMP, CBS-1151-XV+, UL
38	1	1001.00363.00	COVER, UPPER BASE, CBS-1151 EXTRACTOR V+
37	12	1082.00017.00	SCREW, TRUSS HD. PHIL. MACHINE, # 6-32 X 1/2 LG.
36	1	1001.00362.00	COVER, TOP, CBS-1151 EXTRACTOR V+
35	11	1084.00011.00	NUT, CLIP ON (J-NUT), #6-32, 22-20 GA., BLK-PH FINISH
34	1	1086.00009.00	CLAMP, 3/4" MAX TUBE OD FLOW CONTROL
33	1	1025.00058.00	TUBE, 9/16"OD X 5/16"ID X 25.00"LG
32	4	1086.00003.00	UNICLAMP, 15.9 HOSE OD CLAMP
31	1	1025.00082.00	TUBE, 5/8"OD X 3/8"ID X 19.00"LG.
30	2	1029.00006.00	NUT, FINGER, #4-40 NYLON
29	1	1102.00113.00	SWITCH, REED, ASSEMBLY
28	1	1086.00017.00	HEYCO HOSE CLAMP DIA .1.031-1.187
27	1	1086.00018.00	HEYCO HOSE CLAMP DIA. .875-1.00
26	1	1025.00021.00	TUBE, 31/32"OD X 5/8"ID X 4 1/4"LG, BREW
25	6	1083.00010.00	WASHER, #10 SCREW W/NEOPRENE-BONDED SEAL
24	1	1102.00223.01	SPRAY HOUSING, LARGE, 24 VDC, STRONGER COIL
23	1	1084.00010.00	NUT, HEX, #6-32, UNDERSIZED, ZINC PLATED
22	1	1083.00009.00	WASHER, #6 SCREW, INTL TOOTH LOCKWASHER
21	1	1102.00375.00	ASSEMBLY, FRONT PANEL, CBS-1100 SINGLE
20	1	1084.00048.00	JAM NUT, 1/2-20 UNF, NICKEL PLATED BRASS
19	1	1071.00055.00	FAUCET, HOT WATER, PSC-BR-8, WITH FLAT AND STEM
18	1	1046.00051.00	LABEL, "WARNING, EXTREMELY HOT WATER"
17	1	1058.00024.00	SWITCH, POWER, DOUBLE POLE, 16A, 125/250 VAC
16	1	1044.00012.00	LABEL GROUND, CE
15	1	1065.00009.00	GROUND LUG CONNECTOR, 14-2 AWG, ALUMINUM
14	2	1082.00082.00	SCREW, PHILLIP HD., 8-32 THREAD
13	1	1052.00025.00	PLATE, MARKING #BS1016E
12	1	1052.00023.00	EUROSTRIP HE16 TERMINAL BLOCK, 4 POLE, 63 AMP, 18-8 AWG
11	13	1084.00006.00	NUT, 8-32 18-8 HEX MACHINE SCREW
10	5	1083.00011.00	WASHER, #8 SCREW SIZE, INTERNAL TOOTH LOCK
9	1	1112.00268.00	WELDMENT, BRACKET TERMINAL BLOCK, 4 POLE
8	4	1029.00012.00	SPACER, .25" HEX X 1" LG, FEM #4-40 THREAD
7	1	1052.00001.00	POWER SUPPLY, 90-264VAC/24VDC, 1.8A
6	8	1081.00006.00	SPACER, 6MM OD X 3.2MM ID X 5MM LG, Z/P
5	1	1102.00243.00	ADAPTER ASSY, 3/4" BSP X 1/4" NPT X 3/8" TUBE
4	2	1082.00010.00	SCREW, M4X10 ZINC-PLATED PAN HD. PHILLIPS MACH.
3	2	1083.00005.00	WASHER, M4 18-8 INTERNAL TOOTH LOCKWASHER
2	1	1057.00043.00	SOLENOID VALVE, 5.5L/min, 180 DEG, 24VDC
1	1	1111.00088.00	WELDMENT, COMPLETE, CBS-1151 XV+

BILL OF MATERIALS			
ITEM NO	QTY	PART NO	DESCRIPTION
TOLERANCES			
UNLESS OTHERWISE SPECIFIED			
ALL DIMENSIONS IN INCHES			
DECIMAL ± .005"			
ANGULAR ± 1/2°			
THIRD-ANGLE			
MATERIAL N/A			
GAUGE N/A			
FINISH N/A			

**FETCO** FOOD EQUIPMENT TECHNOLOGIES COMPANY  
 600 ROSE ROAD, LAKE ZURICH, IL 60047, USA  
 PHONE: (800) 338-2699 FAX: (847) 719-3001  
 E-MAIL: engineering@fetco.com www.fetco.com

DRAWING NAME:  
**ASSEMBLY, CBS-1151 XV+, COMMON**

CREATED BY: DK DATE: 07/18/2016 DRAWING NO.: 1101.00342.00

DRAWING BY: DK SCALE: 0.125

APP'D BY: AG SHEETS: 1 of 11 REVISION: A

PROPRIETARY AND CONFIDENTIAL.  
 THE INFORMATION CONTAINED IN THIS DRAWING IS THE SOLE PROPERTY OF FETCO.  
 ANY REPRODUCTION IN PART OR AS A WHOLE WITHOUT THE WRITTEN PERMISSION OF FETCO IS PROHIBITED.

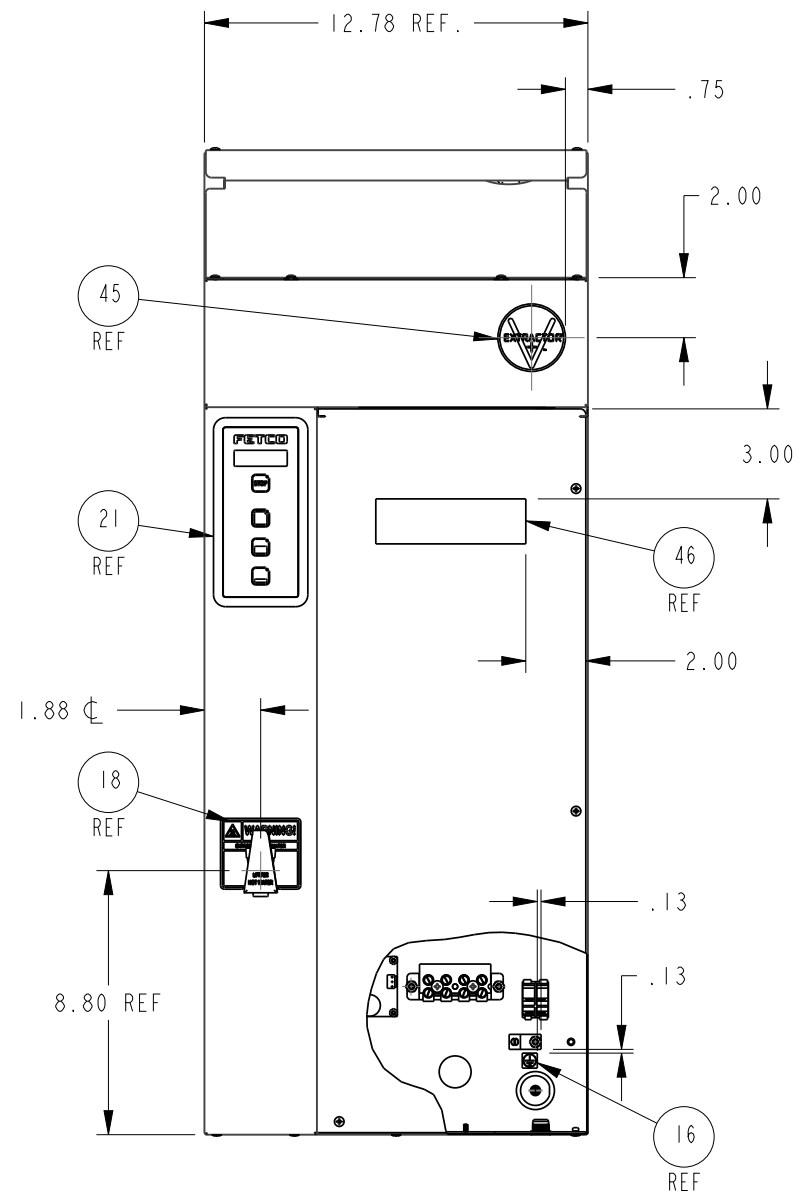

SECTION A-A

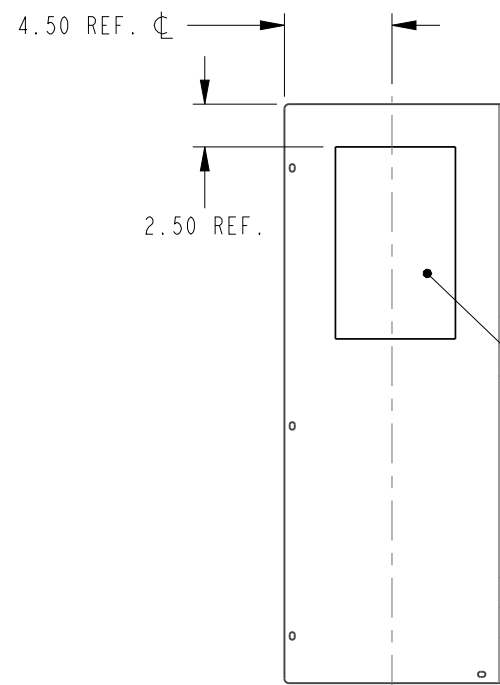
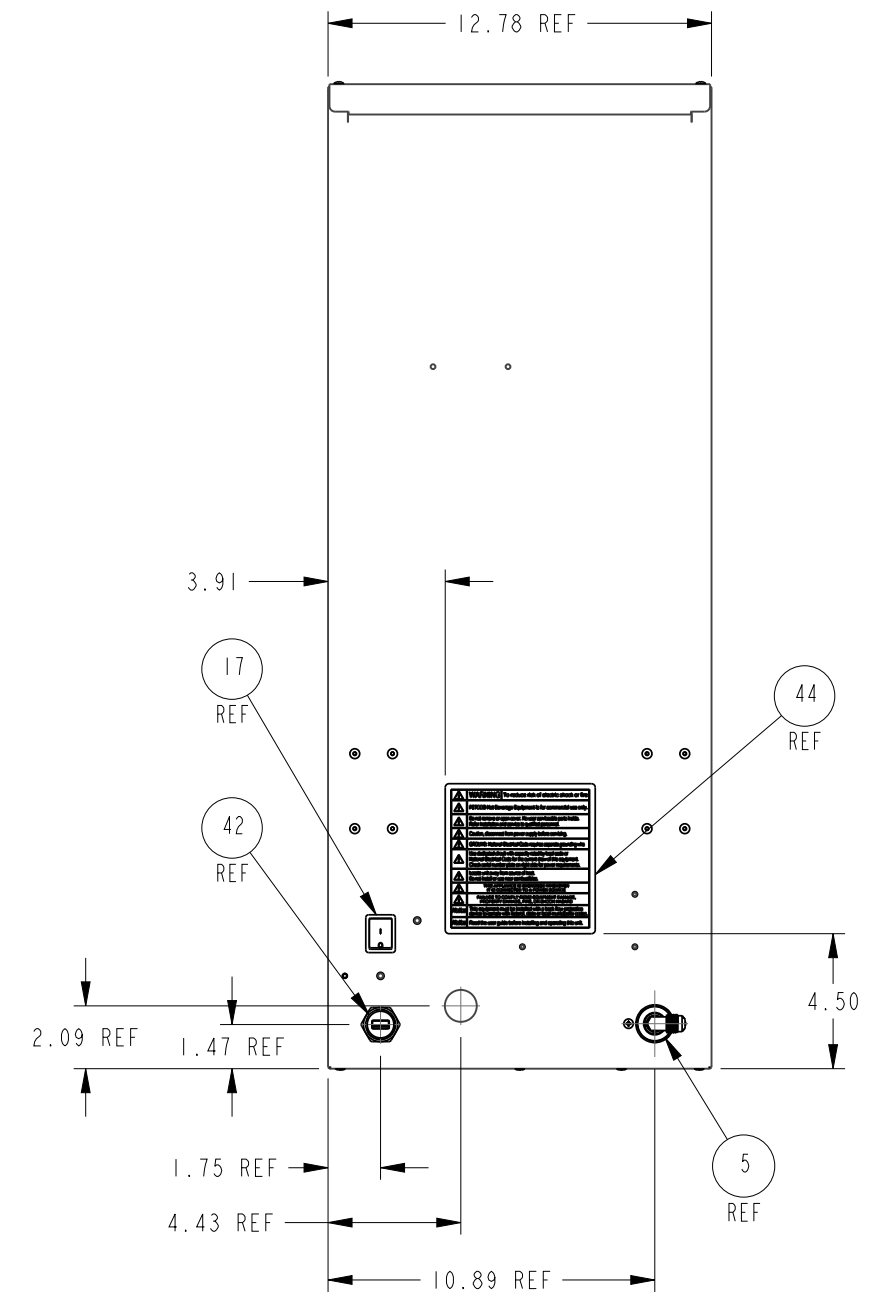
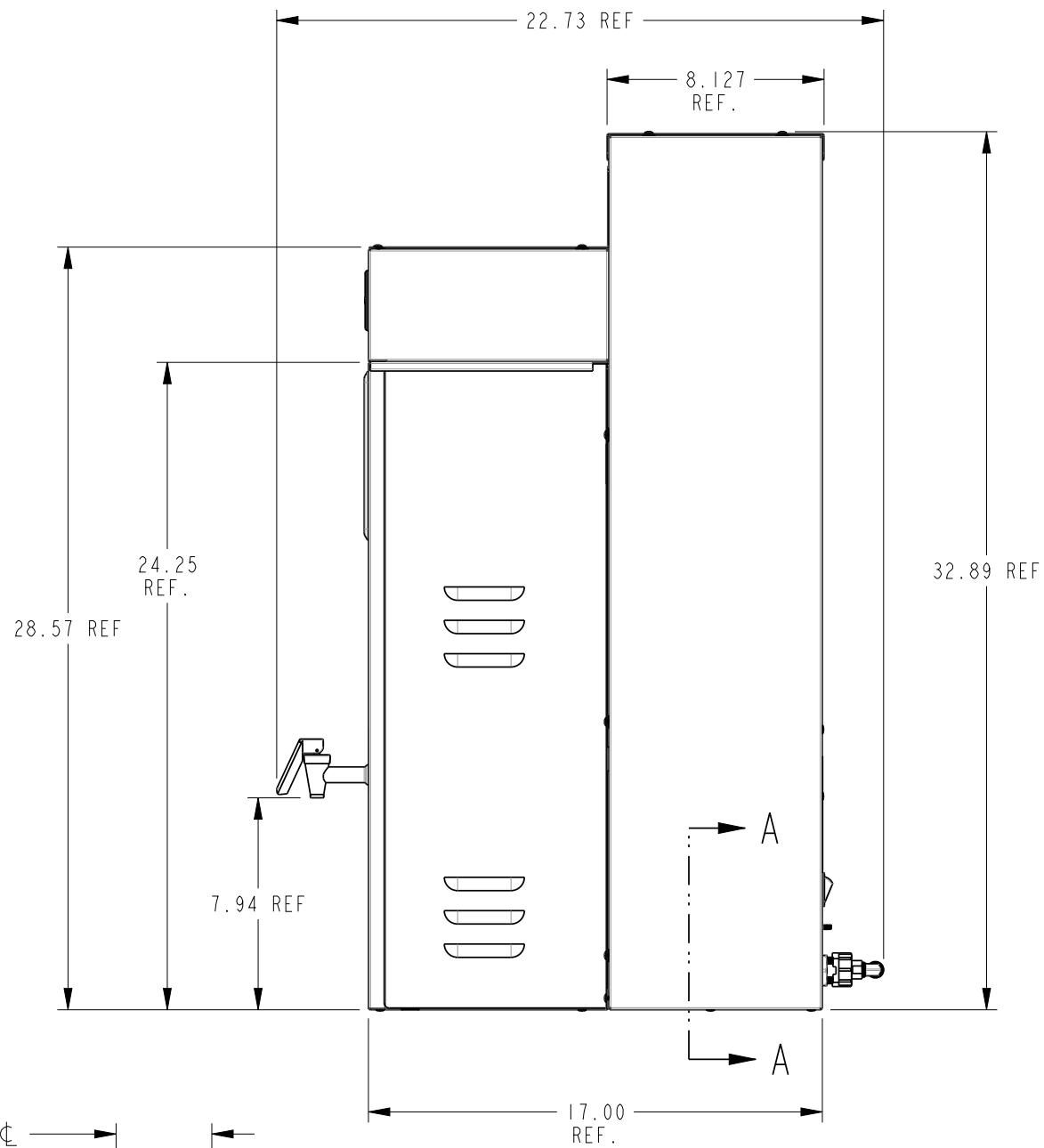

SCHEMATIC ON THE BACK OF ITEM 41,  
1112.00470.00

POSITION LABELS AS SHOWN

PROPRIETARY AND CONFIDENTIAL.  
THE INFORMATION CONTAINED IN THIS DRAWING IS THE SOLE PROPERTY OF FETCO.  
ANY REPRODUCTION IN PART OR AS A WHOLE WITHOUT THE WRITTEN PERMISSION OF FETCO IS PROHIBITED.

TOLERANCES		FETCO® FOOD EQUIPMENT TECHNOLOGIES COMPANY	
UNLESS OTHERWISE SPECIFIED		600 ROSE ROAD, LAKE ZURICH, IL 60047, USA PHONE: (800) 338-2699 FAX: (847) 719-3001 E-MAIL: engineering@fetco.com www.fetco.com	
ALL DIMENSIONS IN INCHES		DRAWING NAME: <b>ASSEMBLY, CBS-1151 XV+, COMMON</b>	
ALL DECIMAL ± .005"	ANGULAR ± 1/2°	THIRD-ANGLE	
CREATED BY: DK	DATE: 07/18/2016	DRAWING NO.:	<b>1101.00342.00</b>
DRAWING BY: DK	SCALE: 0.156	REVISION:	
APP'D BY: AG	SHEETS: 2 of 11	FINISH:	N/A
MATERIAL: N/A	GAUGE: N/A		

REVISIONS

REV	DATE	ECO NO	DESCRIPTION	BY:	A
A	07/18/2016	N/A	ORIGINAL	DK	

SKU # E11511 - B015280BN2 (BROWN PLUG)  
 SKU # 11511M - B001280B1 (BLACK HANDLE)  
 BB ASSEMBLY, 16" x 6", Ø.280" HOLE

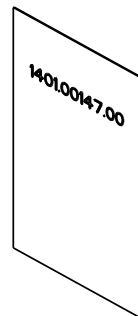
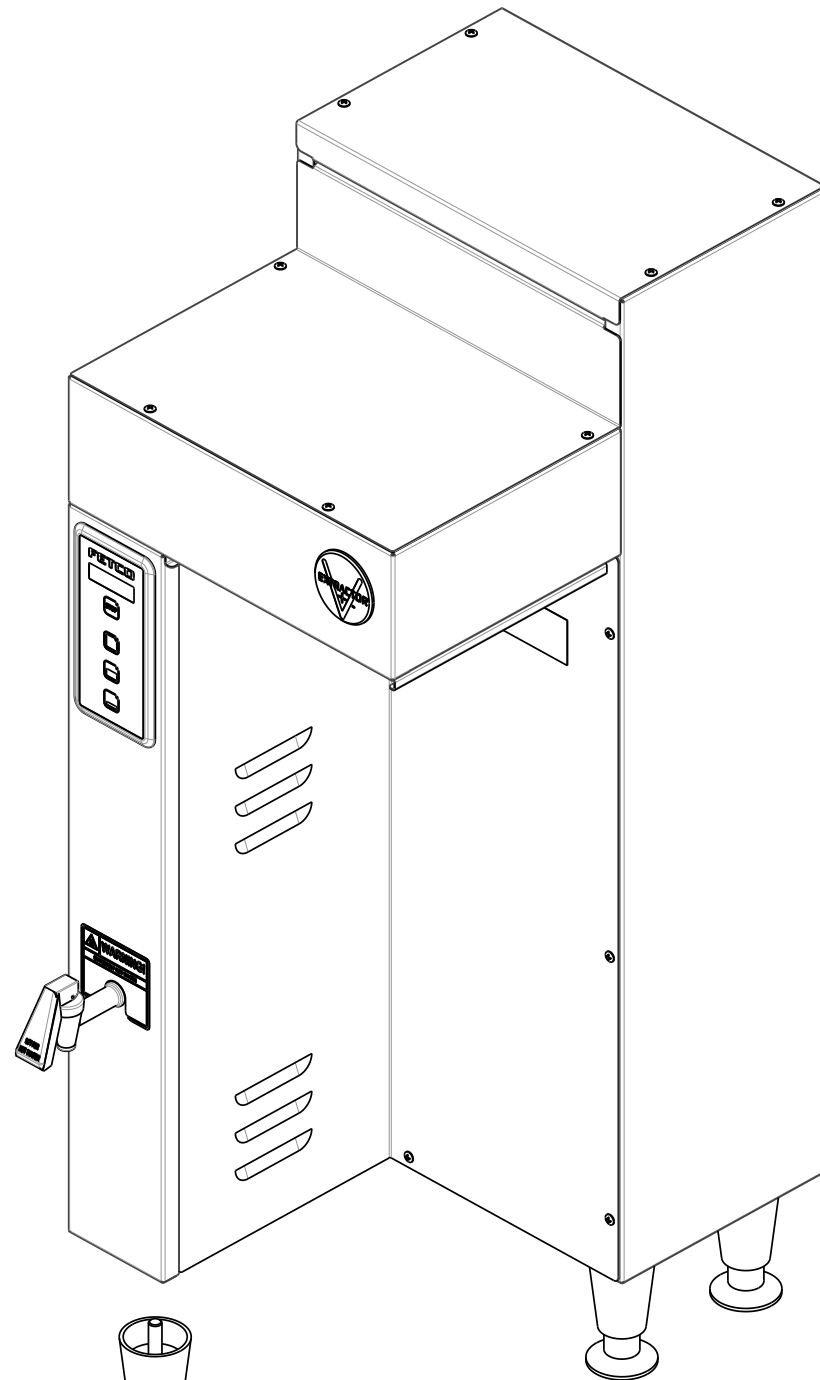
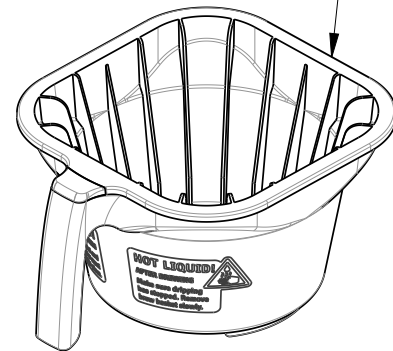

1401.00147.00  
 WIRING, CBS-1151 XV+  
 (L1, L2 + GND), 2 HEATERS, UL

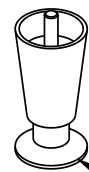

4X 1073.00007.00  
 LEG, FLANGE FOOT,  
 4" HIGH

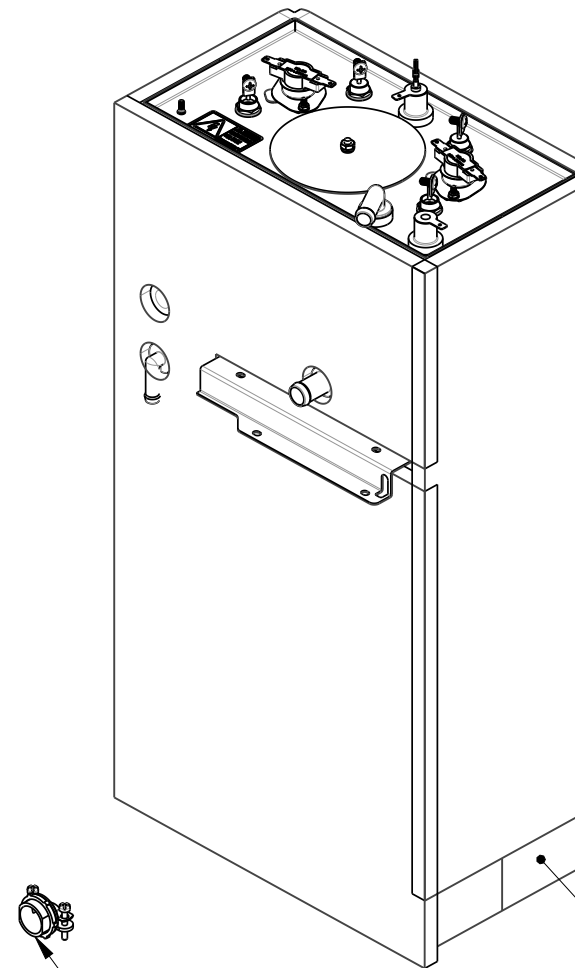

1104.00061.01  
 TANK ASSEMBLY, CBS-1151 XV+  
 2 x 3kW/240VAC



1086.00008.00  
 CONNECTING CLAMP

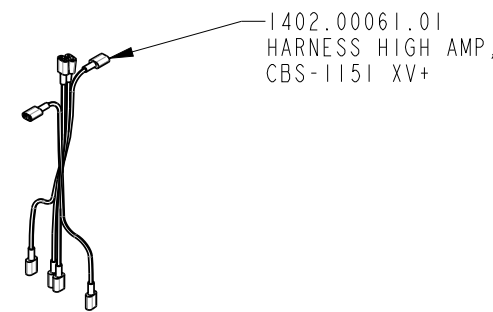

1402.00061.01  
 HARNESS HIGH AMP,  
 CBS-1151 XV+

**E11511 & E11511M**  
 (IDENTICAL TO 1101.00342.00 EXCEPT AS NOTED)

PROPRIETARY AND CONFIDENTIAL.  
 THE INFORMATION CONTAINED IN THIS DRAWING IS THE SOLE PROPERTY OF FETCO.  
 ANY REPRODUCTION IN PART OR AS A WHOLE WITHOUT THE WRITTEN PERMISSION OF FETCO IS PROHIBITED.

TOLERANCES		FETCO® FOOD EQUIPMENT TECHNOLOGIES COMPANY	
UNLESS OTHERWISE SPECIFIED		600 ROSE ROAD, LAKE ZURICH, IL 60047, USA PHONE: (800) 338-2699 FAX: (847) 719-3001 E-MAIL: engineering@fetco.com www.fetco.com	
ALL DIMENSIONS IN INCHES		DRAWING NAME: <b>CBS-1151 XV†, 1Ph, 2IG, 2 X 3kW/240VAC, 208-240VAC</b>	
ALL DECIMAL ± .005" ANGULAR ± 1/2°	THIRD-ANGLE	CREATED BY: DK	DATE 07/18/2016
		DRAWING BY: DK	SCALE 0.188
		APP'D BY: AG	SHEETS 3 of 11
MATERIAL N/A	GAUGE N/A	DRAWING NO. <b>E11511</b>	
		REVISION <b>A</b>	
		FINISH N/A	

REVISIONS				
REV	DATE	ECO NO	DESCRIPTION	BY:
A	07/18/2016	N/A	ORIGINAL	DK

**A**

B002280B1 (BLACK HANDLE W/ CLIPS)  
BB ASSEMBLY, 16" x 6", Ø.280" HOLE

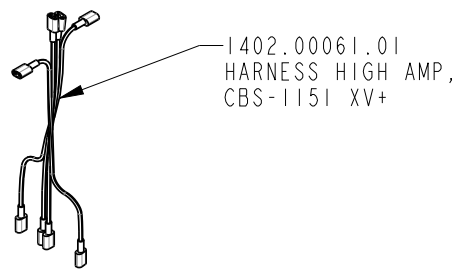
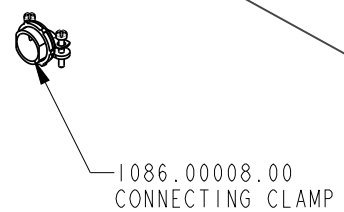
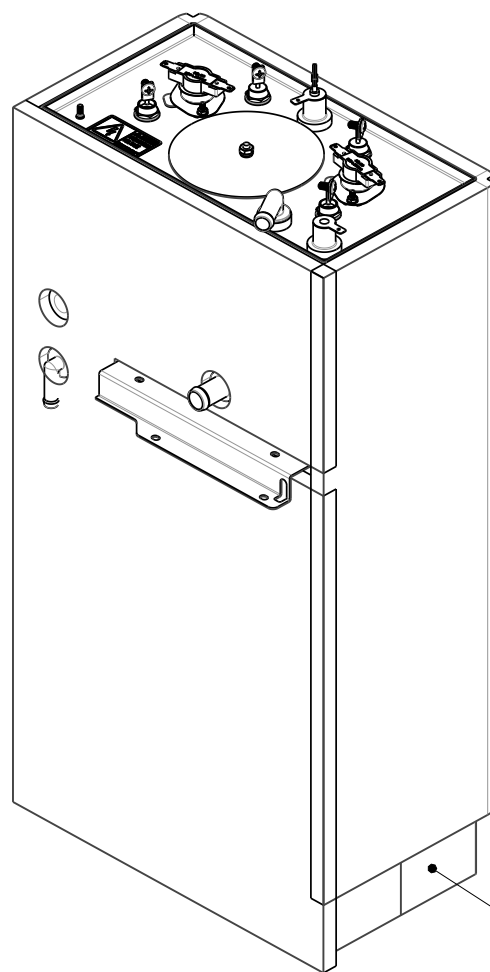
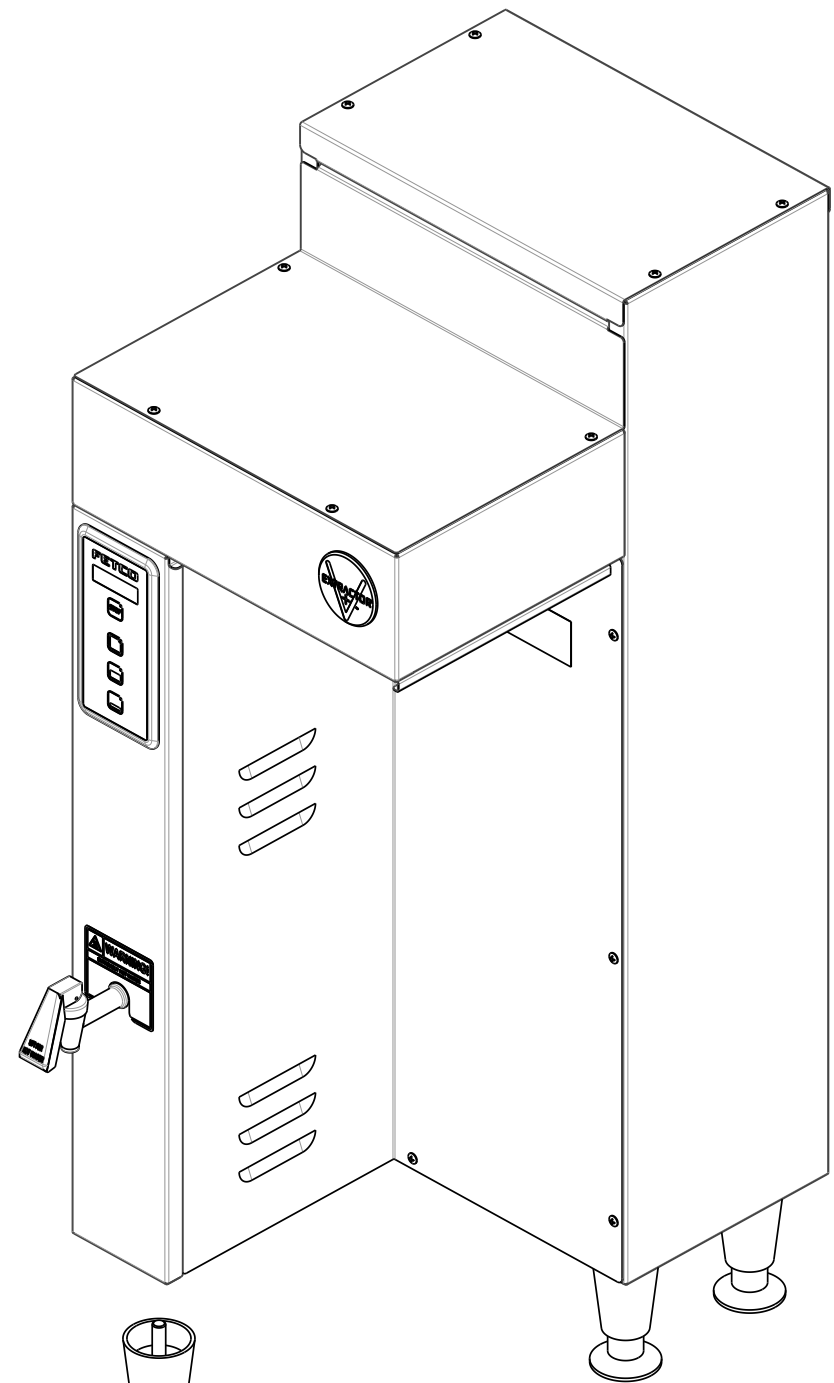
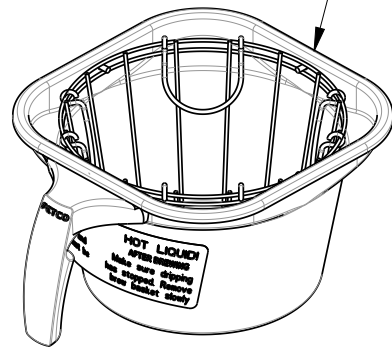

1104.00061.01  
TANK ASSEMBLY, CBS-1151 XV+  
2 x 3kW/240VAC

1086.00008.00  
CONNECTING CLAMP

1402.00061.01  
HARNESS HIGH AMP,  
CBS-1151 XV+

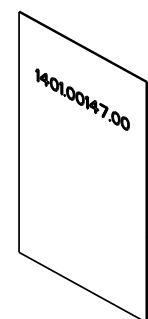

1401.00147.00  
WIRING, CBS-1151 XV+  
(L1, L2 + GND), 2 HEATERS, UL

4X 1073.00007.00  
LEG, FLANGE FOOT,  
4" HIGH

**E115151ROYAL**  
(IDENTICAL TO 1101.00342.00 EXCEPT AS NOTED)

TOLERANCES		FETCO® FOOD EQUIPMENT TECHNOLOGIES COMPANY	
UNLESS OTHERWISE SPECIFIED	ALL DIMENSIONS IN INCHES	600 ROSE ROAD, LAKE ZURICH, IL 60047, USA	PHONE: (800) 338-2699 FAX: (847) 719-3001
ALL DECIMAL ± .005"	ANGULAR ± 1/2°	E-MAIL: engineering@fetco.com	www.fetco.com
THIRD-ANGLE		DRAWING NAME: <b>CBS-1151 XV+, 1Ph, 2IG, 2 X 3kW/240VAC, 208-240VAC, ROYAL CUP</b>	
MATERIAL	N/A	CREATED BY: DK	DATE 07/18/2016
		DRAWING BY: DK	SCALE 0.188
		APP'D BY: AG	SHEETS 4 of 11
			DRAWING NO. <b>E115151ROYAL</b>
			REVISION <b>A</b>
			FINISH N/A

PROPRIETARY AND CONFIDENTIAL.  
THE INFORMATION CONTAINED IN THIS DRAWING IS THE SOLE PROPERTY OF FETCO.  
ANY REPRODUCTION IN PART OR AS A WHOLE WITHOUT THE WRITTEN PERMISSION OF FETCO IS PROHIBITED.

REVISIONS

REV	DATE	ECO NO	DESCRIPTION	BY:	A
A	07/18/2016	N/A	ORIGINAL	DK	

SKU # E115161 - B015280BN2 (BROWN PLUG)  
 SKU # E115161M - B001280B1 (BLACK HANDLE)  
 BB ASSEMBLY, 16" x 6", Ø.280" HOLE

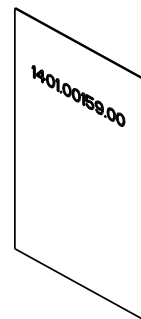
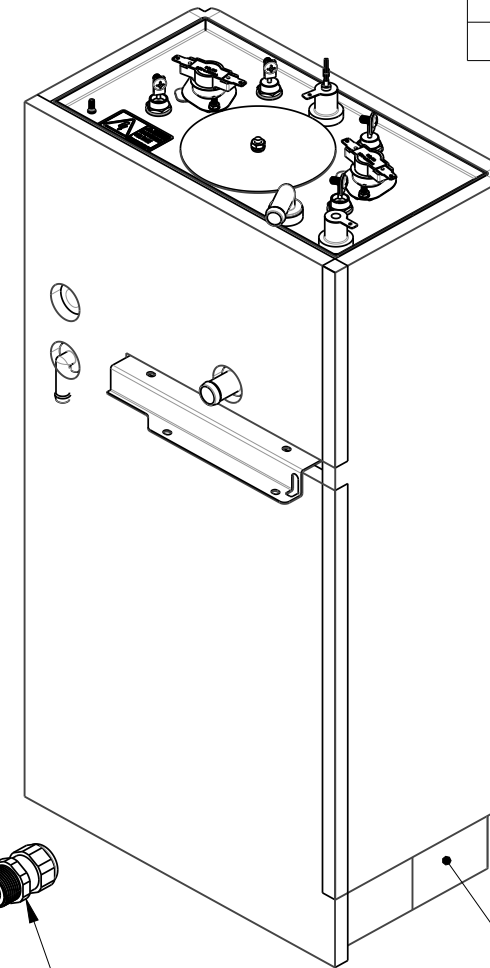
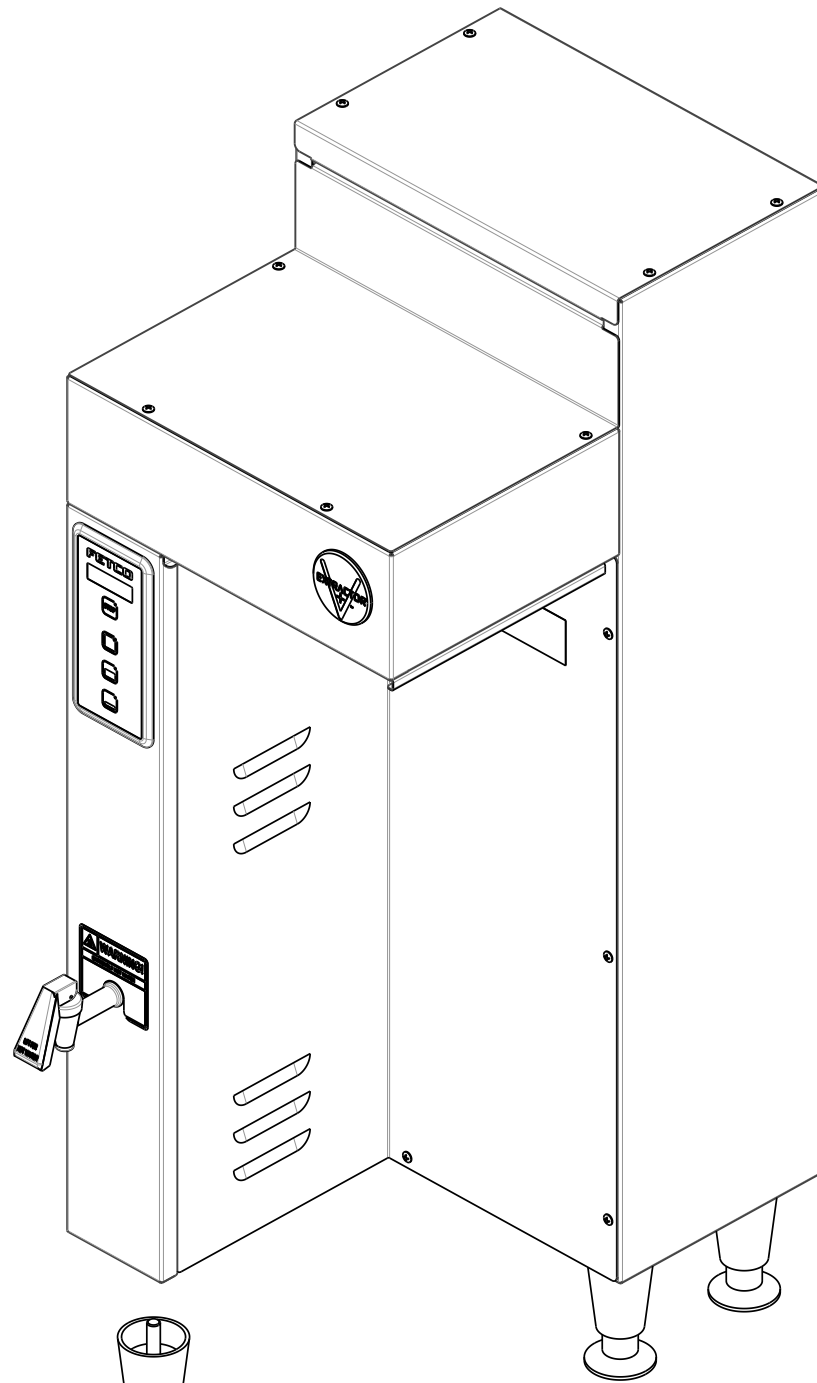
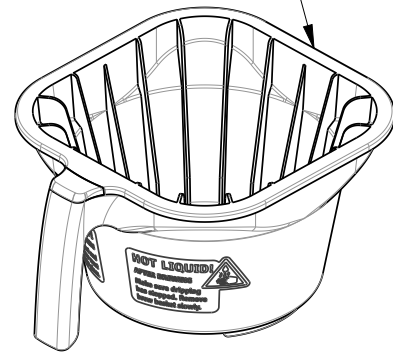

4X 1073.00007.00  
 LEG, FLANGE FOOT,  
 4" HIGH

1401.00159.00  
 WIRING DIAGRAM, CBS-1151 XV+  
 UNIVERSAL, 2 HEATERS, CE

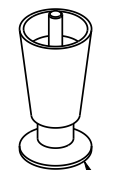

4X 1084.00012.00  
 #6-32 HEX NUT

4X 1083.00009.00  
 #6 INT. TOOTH WASHER

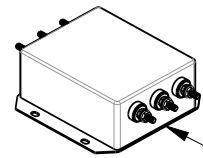

1052.00036.00  
 EMI FILTER, THREE LINE 20A  
 250/440VAC

1086.00031.00  
 CONNECTING CLAMP

1044.00013.00  
 LABEL, EQUIPOTENTIALITY, CE

1084.00006.00  
 #8-32 HEX NUT

1083.00011.00  
 #8 INT. TOOTH WASHER

1065.00009.00  
 GROUND LUG CONNECTOR

1402.00050.01  
 HARNESS HIGH AMP CE,  
 CBS-1151 XV+

1104.00061.01  
 TANK ASSEMBLY, CBS-1151 XV+  
 2 x 3kW/240VAC

**E115161 & E115161M**  
 (IDENTICAL TO 1101.00342.00 EXCEPT AS NOTED)

PROPRIETARY AND CONFIDENTIAL.  
 THE INFORMATION CONTAINED IN THIS DRAWING IS THE SOLE PROPERTY OF FETCO.  
 ANY REPRODUCTION IN PART OR AS A WHOLE WITHOUT THE WRITTEN PERMISSION OF FETCO IS PROHIBITED.

TOLERANCES		FETCO® FOOD EQUIPMENT TECHNOLOGIES COMPANY	
UNLESS OTHERWISE SPECIFIED		600 ROSE ROAD, LAKE ZURICH, IL 60047, USA PHONE: (800) 338-2699 FAX: (847) 719-3001 E-MAIL: engineering@fetco.com www.fetco.com	
ALL DIMENSIONS IN INCHES		DRAWING NAME: <b>CBS-1151 XV<sup>†</sup>, 2Ph, 2L,N,PE, 2 X 3kW/240VAC, 230/400VAC, CE</b>	
ALL DECIMAL ± .005"	CREATED BY: DK	DATE: 07/18/2016	DRAWING NO.:
ANGULAR ± 1/2°	DRAWING BY: DK	SCALE: 0.188	<b>E115161</b>
THIRD-ANGLE	APP'D BY: AG	SHEETS: 5 of 11	REVISION: <b>A</b>
MATERIAL: N/A	GAUGE: N/A	FINISH: N/A	

REVISIONS				
REV	DATE	ECO NO	DESCRIPTION	BY:
A	07/18/2016	N/A	ORIGINAL	DK

**A**

SKU # E115162 - B015280BN2 (BROWN PLUG)  
 SKU # E115162M - B001280B1 (BLACK HANDLE)  
 BB ASSEMBLY, 16" x 6", Ø.280" HOLE

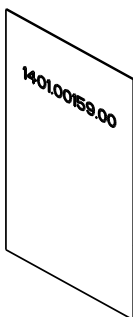
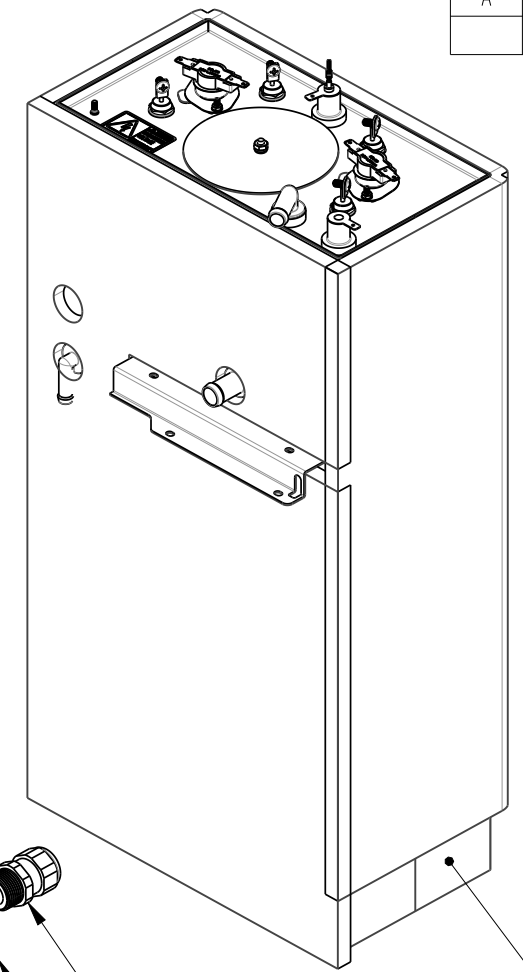
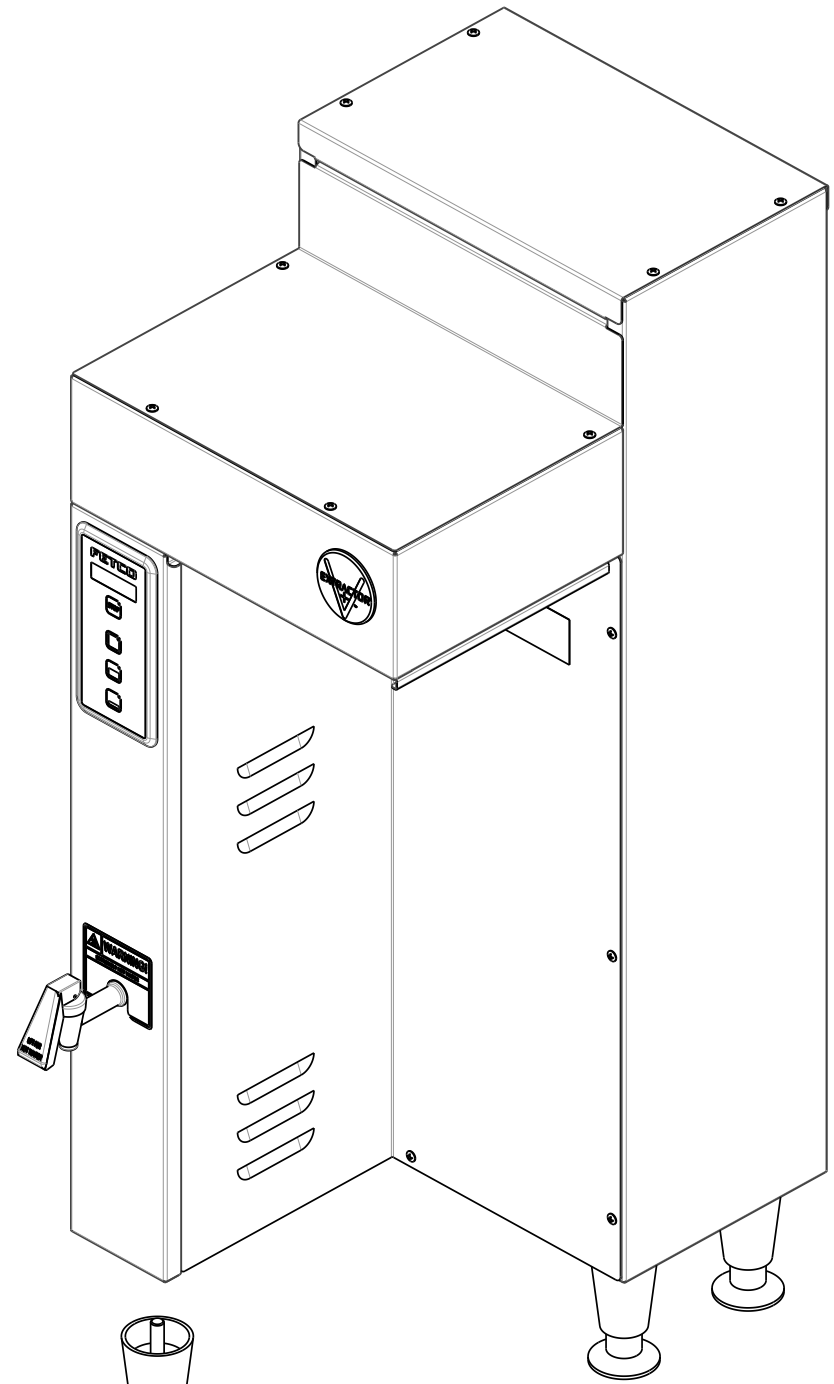
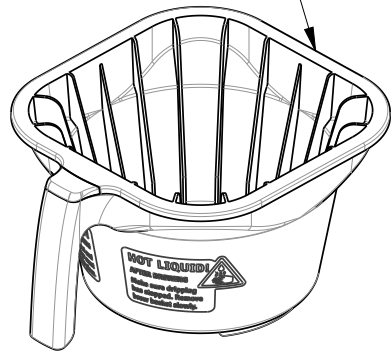

4X 1073.00007.00  
 LEG, FLANGE FOOT,  
 4" HIGH

1401.00159.00  
 WIRING DIAGRAM, CBS-1151 XV+  
 UNIVERSAL, 2 HEATERS, CE

4X 1084.00012.00  
 #6-32 HEX NUT

4X 1083.00009.00  
 #6 INT. TOOTH WASHER

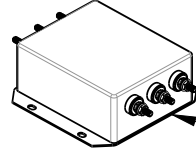

1052.00036.00  
 EMI FILTER, THREE LINE 20A  
 250/440VAC

1086.00031.00  
 CONNECTING CLAMP

1044.00013.00  
 LABEL, EQUIPOTENTIALITY, CE

1084.00006.00  
 #8-32 HEX NUT

1083.00011.00  
 #8 INT. TOOTH WASHER

1065.00009.00  
 GROUND LUG CONNECTOR

1402.00050.01  
 HARNESS HIGH AMP CE,  
 CBS-1151 XV+

1104.00096.01  
 TANK ASSEMBLY, CBS-1151 XV+  
 2 x 2.3kW/240VAC

**E115162 & E115162M**  
 (IDENTICAL TO 1101.00342.00 EXCEPT AS NOTED)

TOLERANCES		FETCO® FOOD EQUIPMENT TECHNOLOGIES COMPANY	
UNLESS OTHERWISE SPECIFIED		600 ROSE ROAD, LAKE ZURICH, IL 60047, USA PHONE: (800) 338-2699 FAX: (847) 719-3001 E-MAIL: engineering@fetco.com www.fetco.com	
DRAWING NAME: <b>CBS-1151 XV+, 1Ph, L,N,PE, 2 X 2.3kW/240VAC, 230VAC, CE</b>			
ALL DIMENSIONS IN INCHES	CREATED BY: DK	DATE 07/18/2016	DRAWING NO. <b>E115162</b>
ALL DECIMAL ± .005" ANGULAR ± 1/2°	DRAWING BY: DK	SCALE 0.188	REVISION <b>A</b>
THIRD-ANGLE	APP'D BY: AG	SHEETS 6 of 11	
MATERIAL N/A	GAUGE N/A	FINISH N/A	

PROPRIETARY AND CONFIDENTIAL.  
 THE INFORMATION CONTAINED IN THIS DRAWING IS THE SOLE PROPERTY OF FETCO.  
 ANY REPRODUCTION IN PART OR AS A WHOLE WITHOUT THE WRITTEN PERMISSION OF FETCO IS PROHIBITED.

REVISIONS				
REV	DATE	ECO NO	DESCRIPTION	BY:
A	07/18/2016	N/A	ORIGINAL	DK

**A**

SKU # E115180 - B015280BN2 (BROWN PLUG)  
 SKU # E115180M - B001280B1 (BLACK HANDLE)  
 BB ASSEMBLY, 16" x 6", Ø.280" HOLE

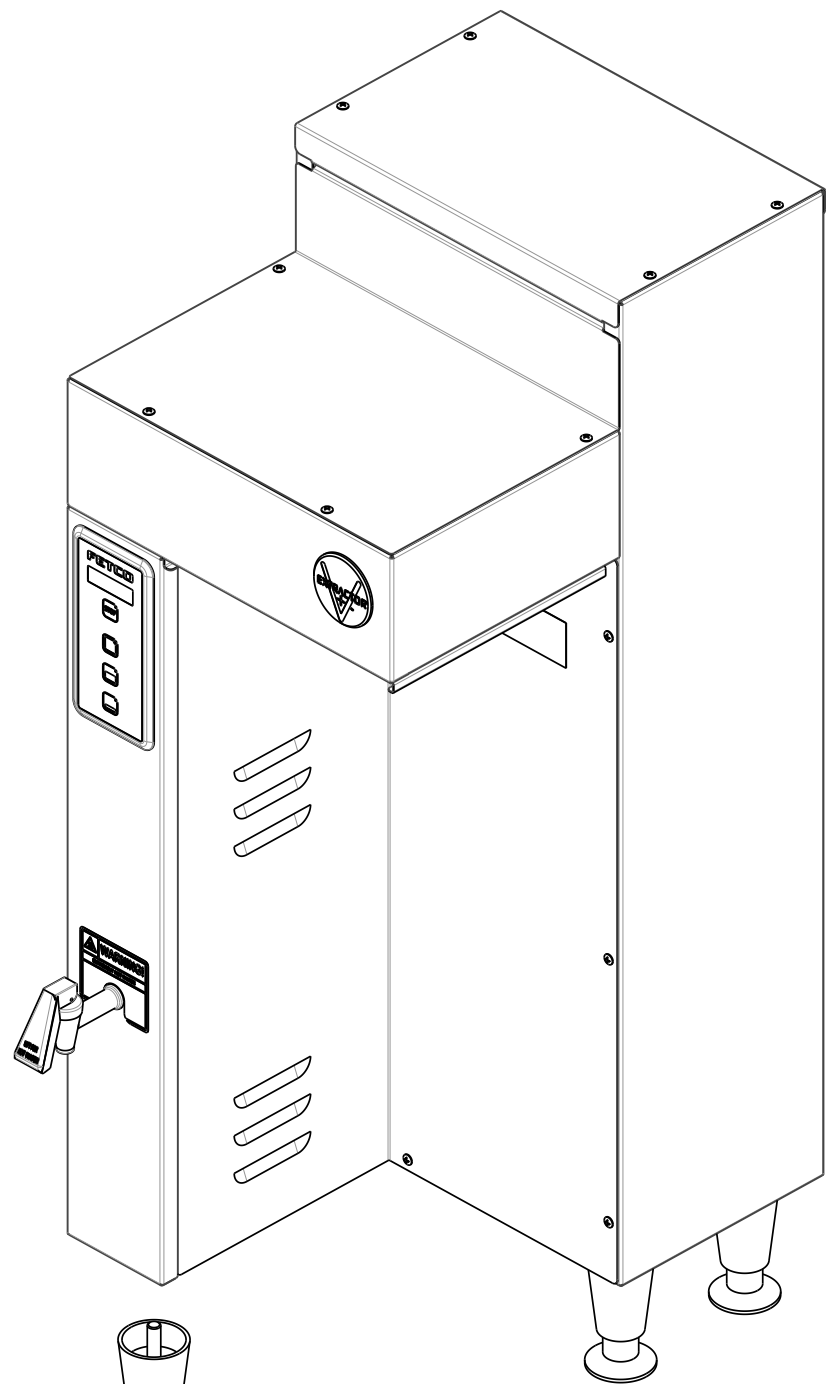
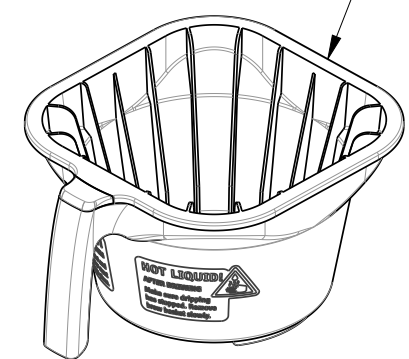

1401.00152.00  
 WIRING, CBS-1151 XV+  
 L1, L2+GND, 1 HEATER, JAPAN

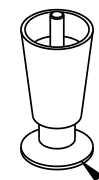

4X 1073.00007.00  
 LEG, FLANGE FOOT,  
 4" HIGH

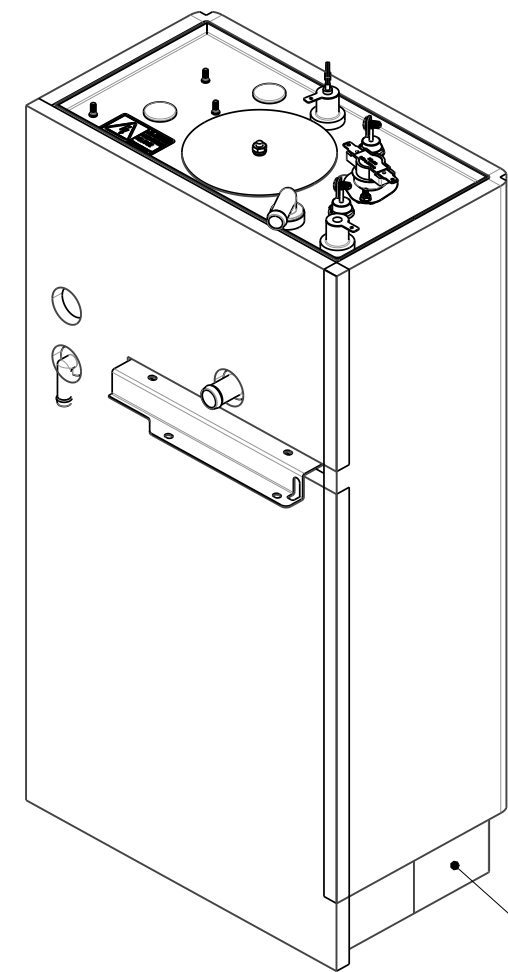

1104.00095.01  
 TANK ASSEMBLY, CBS-1151 XV+  
 5kW/240VAC



1086.00008.00  
 CONNECTING CLAMP

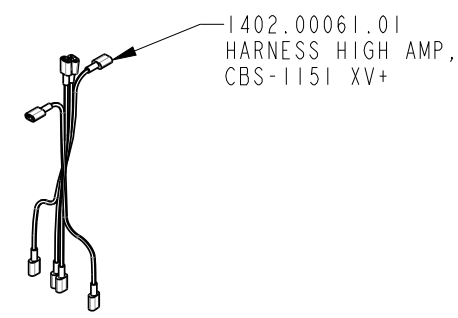

1402.00061.01  
 HARNESS HIGH AMP,  
 CBS-1151 XV+

**E115180 & E115180M**  
 (IDENTICAL TO 1101.00342.00 EXCEPT AS NOTED)

PROPRIETARY AND CONFIDENTIAL.  
 THE INFORMATION CONTAINED IN THIS DRAWING IS THE SOLE PROPERTY OF FETCO.  
 ANY REPRODUCTION IN PART OR AS A WHOLE WITHOUT THE WRITTEN PERMISSION OF FETCO IS PROHIBITED.

TOLERANCES		<b>FETCO</b> FOOD EQUIPMENT TECHNOLOGIES COMPANY	
UNLESS OTHERWISE SPECIFIED		600 ROSE ROAD, LAKE ZURICH, IL 60047, USA PHONE: (800) 338-2699 FAX: (847) 719-3001 E-MAIL: engineering@fetco.com www.fetco.com	
ALL DIMENSIONS IN INCHES		DRAWING NAME: <b>CBS-1151 XV+, 1Ph, 2LG, 5.0kW/240VAC, 200VAC, JAPAN</b>	
ALL DECIMAL ± .005" ANGULAR ± 1/2°		CREATED BY: DK	DATE 07/18/2016
THIRD-ANGLE		DRAWING BY: DK	SCALE 0.188
MATERIAL N/A		APP'D BY: AG	SHEETS 7 of 11
		GAUGE N/A	FINISH N/A
		DRAWING NO. <b>E115180</b>	
		REVISION <b>A</b>	

REVISIONS				
REV	DATE	ECO NO	DESCRIPTION	BY:
A	07/18/2016	N/A	ORIGINAL	DK

**A**

SKU # E115190 - B015280BN2 (BROWN PLUG)  
 SKU # E115190M - B001280B1 (BLACK HANDLE)  
 BB ASSEMBLY, 16" x 6", Ø.280" HOLE

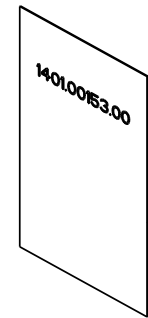
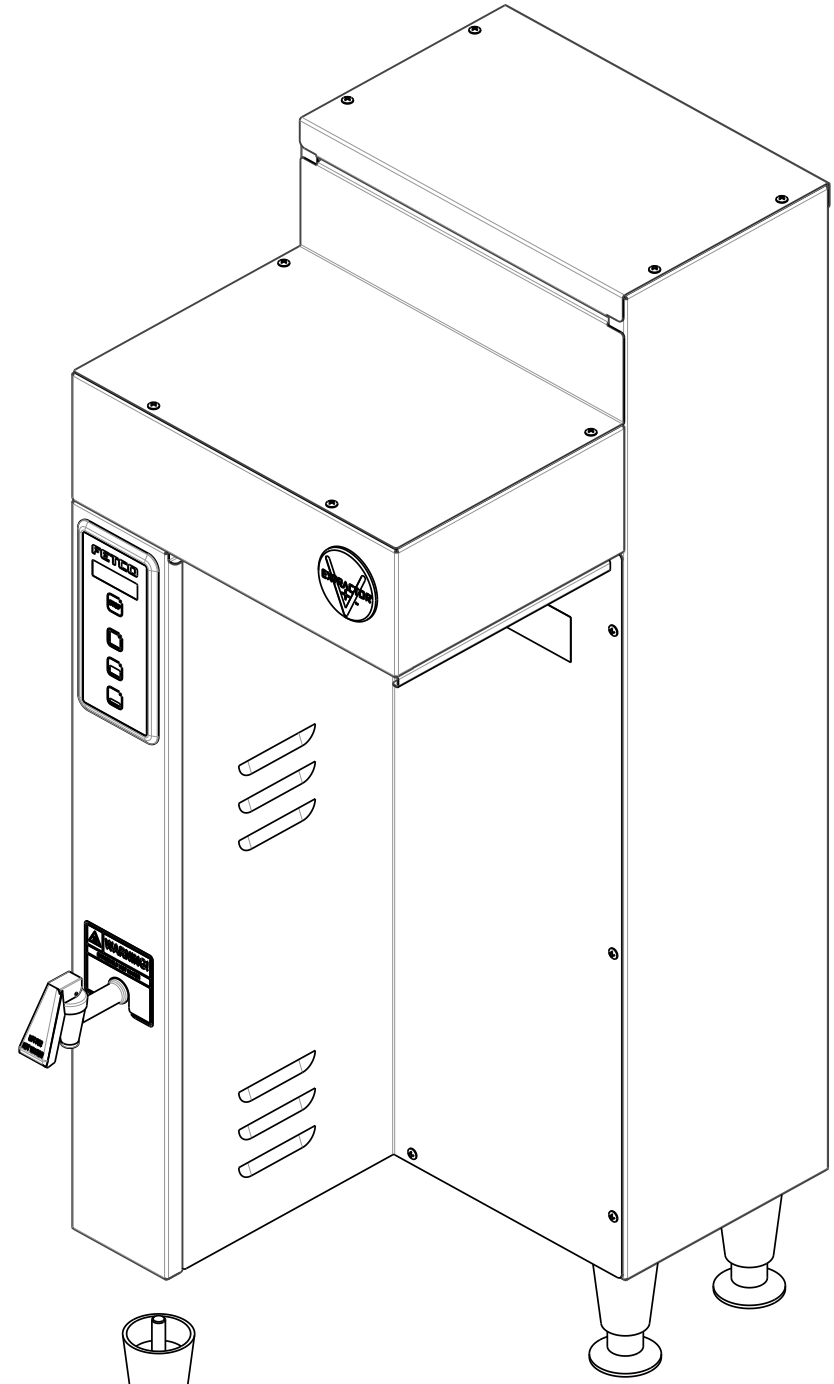
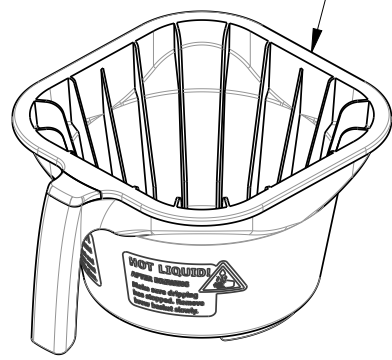

1401.00153.00  
 WIRING, CBS-1151 XV+  
 LI, N + GND, 1 HEATER, EXPORT



4X 1073.00007.00  
 LEG, FLANGE FOOT,  
 4" HIGH

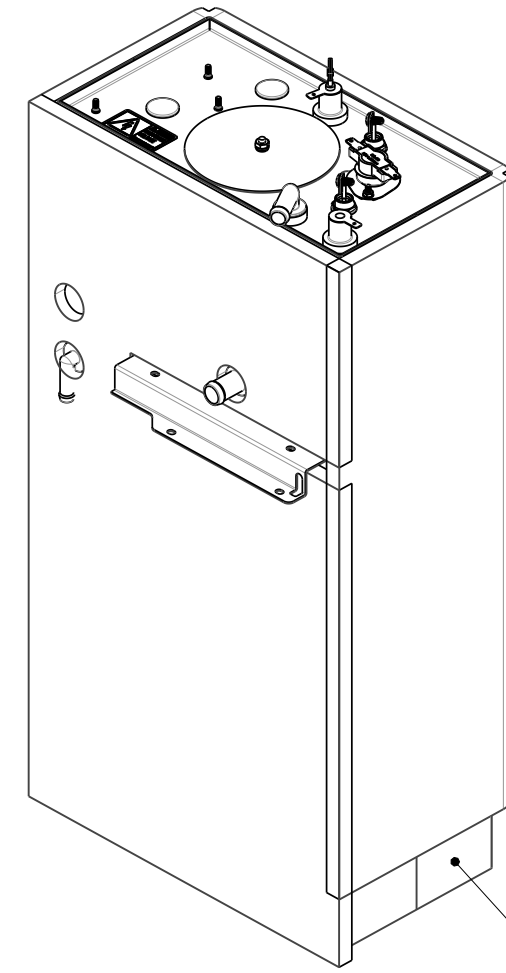

1104.00097.01  
 TANK ASSEMBLY, CBS-1151 XV+  
 4kW/240VAC

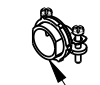

1086.00008.00  
 CONNECTING CLAMP

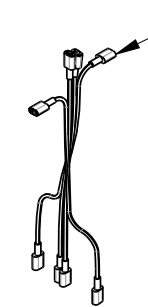

1402.00061.01  
 HARNESS HIGH AMP,  
 CBS-1151 XV+

**E115190 & E115190M**  
 (IDENTICAL TO 1101.00342.00 EXCEPT AS NOTED)

PROPRIETARY AND CONFIDENTIAL.  
 THE INFORMATION CONTAINED IN THIS DRAWING IS THE SOLE PROPERTY OF FETCO.  
 ANY REPRODUCTION IN PART OR AS A WHOLE WITHOUT THE WRITTEN PERMISSION OF FETCO IS PROHIBITED.

TOLERANCES		<b>FETCO</b> FOOD EQUIPMENT TECHNOLOGIES COMPANY	
UNLESS OTHERWISE SPECIFIED		600 ROSE ROAD, LAKE ZURICH, IL 60047, USA PHONE: (800) 338-2699 FAX: (847) 719-3001 E-MAIL: engineering@fetco.com www.fetco.com	
ALL DIMENSIONS IN INCHES		DRAWING NAME: <b>CBS-1151 XV+, 1Ph, 2LG, 4.0kW/240VAC, 200-240VAC, INTL</b>	
ALL DECIMAL ± .005" ANGULAR ± 1/2°	THIRD-ANGLE	CREATED BY: DK	DATE 07/18/2016
		DRAWING BY: DK	SCALE 0.188
		APP'D BY: AG	SHEETS 8 of 11
MATERIAL N/A	GAUGE N/A	DRAWING NO. <b>E115190</b>	
		FINISH N/A	
		REVISION <b>A</b>	



REVISIONS				
REV	DATE	ECO NO	DESCRIPTION	BY:
A	07/18/2016	N/A	ORIGINAL	DK

**A**

SKU # E115191 - B015280BN2 (BROWN PLUG)  
 SKU # E115191M - B001280B1 (BLACK HANDLE)  
 BB ASSEMBLY, 16" x 6", Ø.280" HOLE

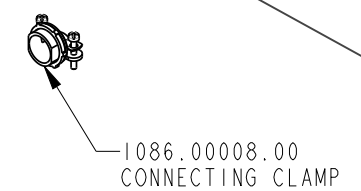
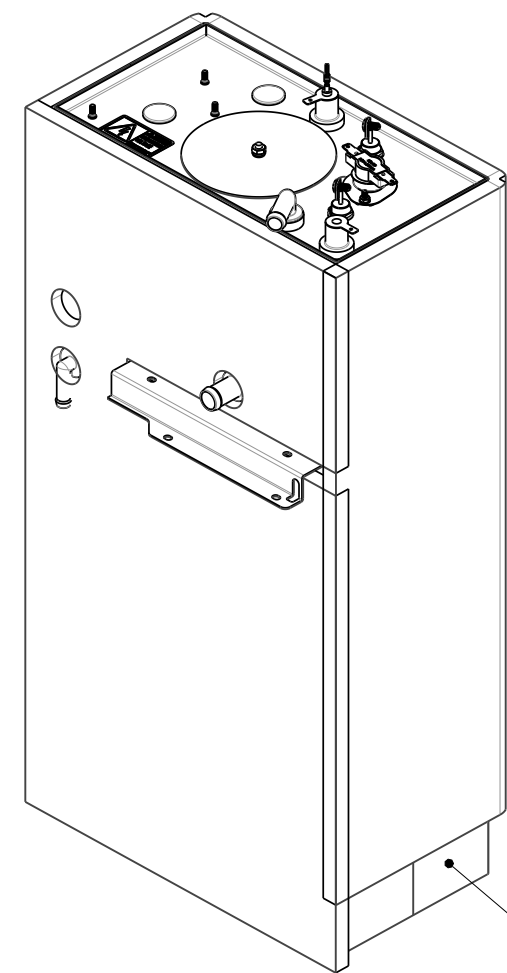
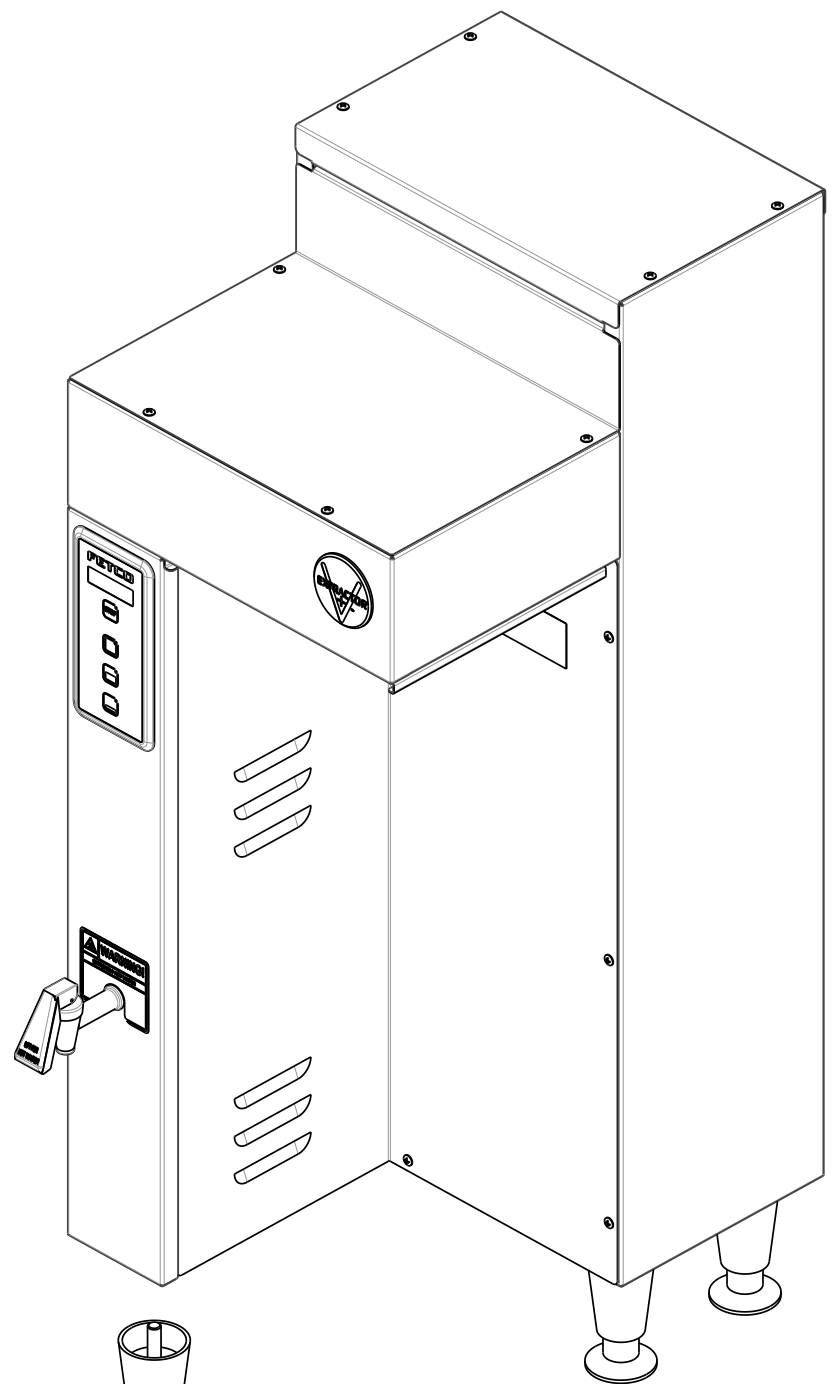
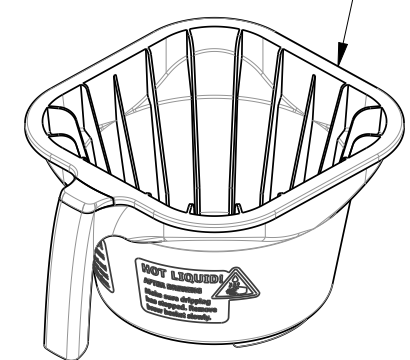

1086.00008.00  
CONNECTING CLAMP

1104.00095.01  
TANK ASSEMBLY, CBS-1151 XV+  
5kW/240VAC

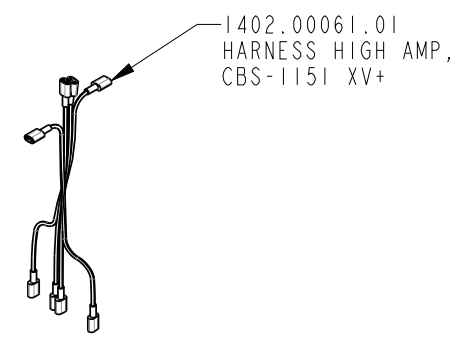

1402.00061.01  
HARNES HIGH AMP,  
CBS-1151 XV+

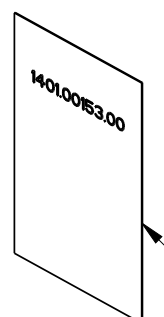

1401.00153.00  
WIRING, CBS-1151 XV+  
L1, N + GND, 1 HEATER, EXPORT

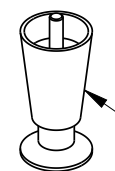

4X 1073.00007.00  
LEG, FLANGE FOOT,  
4" HIGH

**E115191 & E115191M**  
 (IDENTICAL TO 1101.00342.00 EXCEPT AS NOTED)

PROPRIETARY AND CONFIDENTIAL.  
 THE INFORMATION CONTAINED IN THIS DRAWING IS THE SOLE PROPERTY OF FETCO.  
 ANY REPRODUCTION IN PART OR AS A WHOLE WITHOUT THE WRITTEN PERMISSION OF FETCO IS PROHIBITED.

TOLERANCES		<b>FETCO</b> FOOD EQUIPMENT TECHNOLOGIES COMPANY	
UNLESS OTHERWISE SPECIFIED		600 ROSE ROAD, LAKE ZURICH, IL 60047, USA	
ALL DIMENSIONS IN INCHES		PHONE: (800) 338-2699 FAX: (847) 719-3001	
ALL DECIMAL ± .005"		E-MAIL: engineering@fetco.com www.fetco.com	
ANGULAR ± 1/2°		DRAWING NAME:	
THIRD-ANGLE		<b>CBS-1151 XV+, 1Ph, 2+G, 5.0kW/240VAC, 200-240VAC, INTL</b>	
MATERIAL		CREATED BY:	DRAWING NO.
N/A	GAUGE	DK	<b>E115191</b>
	N/A	DATE	REVISION
		07/18/2016	<b>A</b>
		SCALE	
		0.188	
		SHEETS	
		9 of 11	
		FINISH	
		N/A	

REVISIONS				
REV	DATE	ECO NO	DESCRIPTION	BY:
A	07/18/2016	N/A	ORIGINAL	DK

**A**

SKU # E115192 - B015280BN2 (BROWN PLUG)  
 SKU # E115192M - B001280B1 (BLACK HANDLE)  
 BB ASSEMBLY, 16" x 6", Ø.280" HOLE

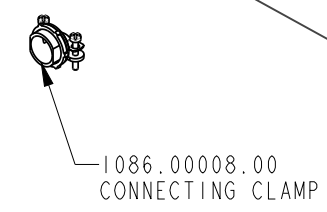
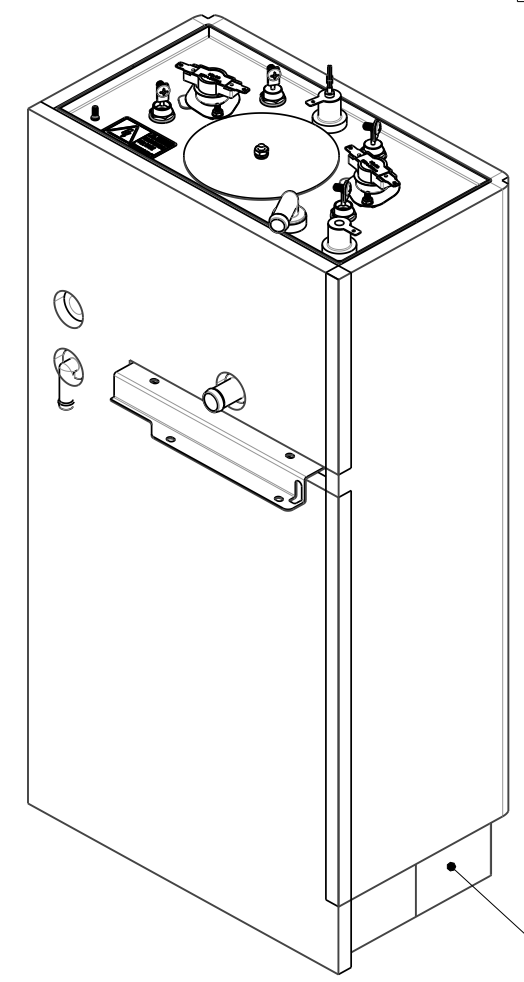
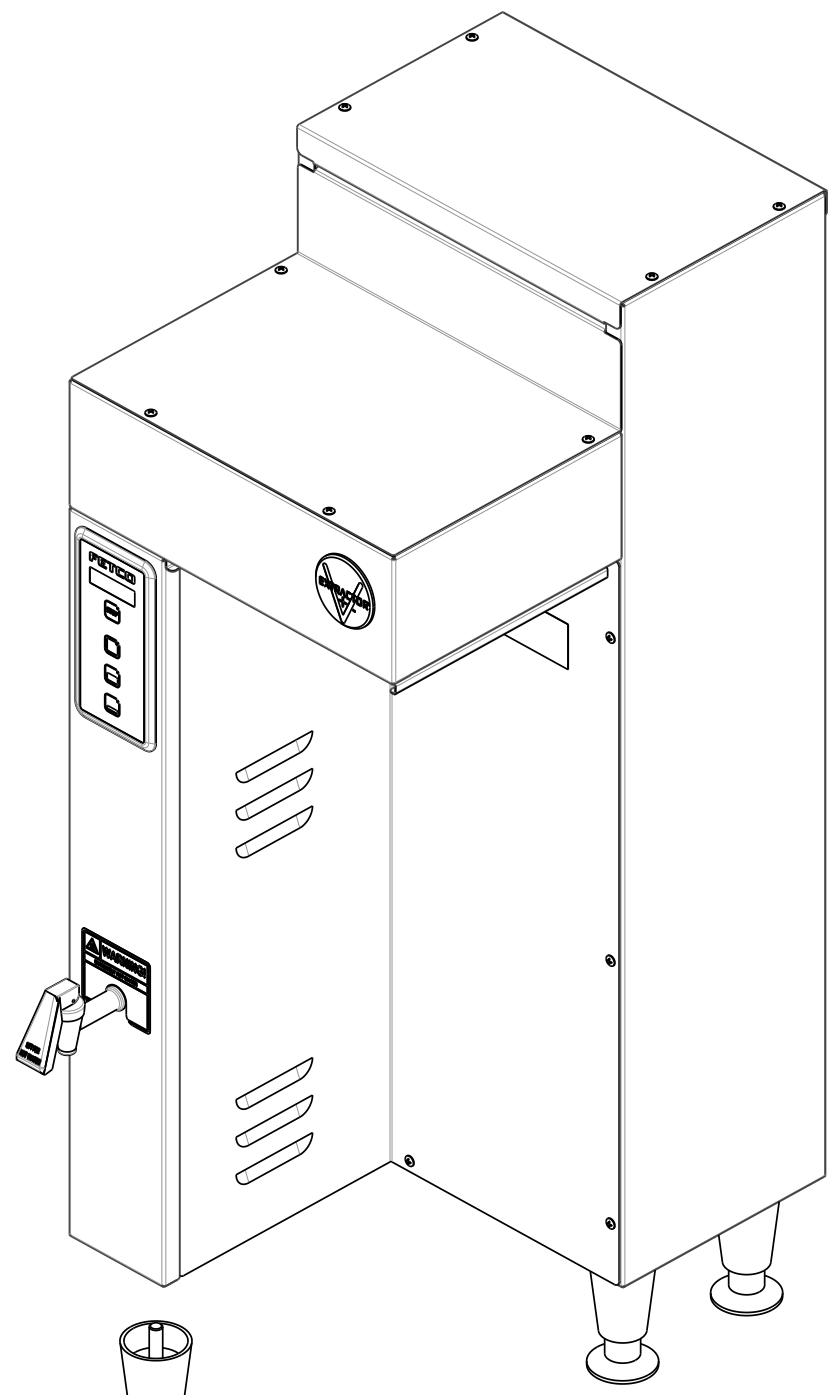
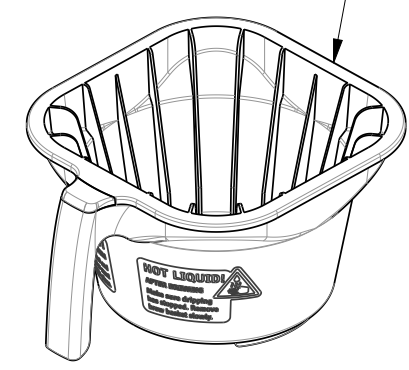

1086.00008.00  
CONNECTING CLAMP

1104.00061.01  
TANK ASSEMBLY, CBS-1151 XV+  
2 x 3kW/240VAC

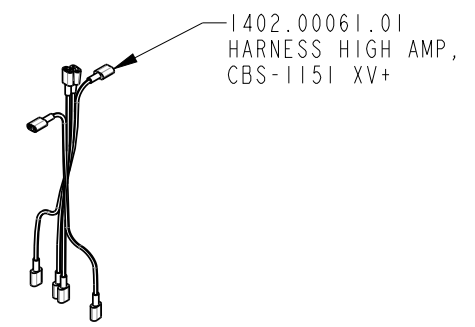

1402.00061.01  
HARNESS HIGH AMP,  
CBS-1151 XV+

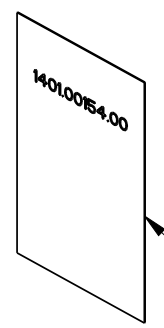

1401.00154.00  
WIRING, CBS-1151 XV+  
L1, N+GND, 2 HEATERS, EXPORT

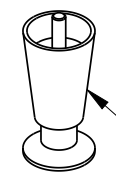

4X 1073.00007.00  
LEG, FLANGE FOOT,  
4" HIGH

**E115192 & E115192M**  
 (IDENTICAL TO 1101.00342.00 EXCEPT AS NOTED)

TOLERANCES		FETCO® FOOD EQUIPMENT TECHNOLOGIES COMPANY	
UNLESS OTHERWISE SPECIFIED		600 ROSE ROAD, LAKE ZURICH, IL 60047, USA PHONE: (800) 338-2699 FAX: (847) 719-3001 E-MAIL: engineering@fetco.com www.fetco.com	
ALL DIMENSIONS IN INCHES		DRAWING NAME: <b>CBS-1151 XV†, 1Ph, 2IG, 2 X 3.0kW/240VAC, 200-240VAC, INTL</b>	
ALL DECIMAL ± .005"	ANGULAR ± 1/2°	THIRD-ANGLE	
CREATED BY: DK	DATE: 07/18/2016	DRAWING NO.:	<b>E115192</b>
DRAWING BY: DK	SCALE: 0.188	REVISION:	
APP'D BY: AG	SHEETS: 10 of 11	FINISH:	<b>A</b>
MATERIAL: N/A	GAUGE: N/A	FINISH: N/A	

PROPRIETARY AND CONFIDENTIAL.  
 THE INFORMATION CONTAINED IN THIS DRAWING IS THE SOLE PROPERTY OF FETCO.  
 ANY REPRODUCTION IN PART OR AS A WHOLE WITHOUT THE WRITTEN PERMISSION OF FETCO IS PROHIBITED.

REVISIONS

REV	DATE	ECO NO	DESCRIPTION	BY:	A
A	07/18/2016	N/A	ORIGINAL	DK	

SKU # E115193 - B015280BN2 (BROWN PLUG)  
 SKU # E115193M - B001280B1 (BLACK HANDLE)  
 BB ASSEMBLY, 16" x 6", Ø.280" HOLE

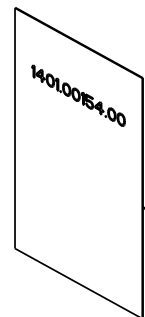
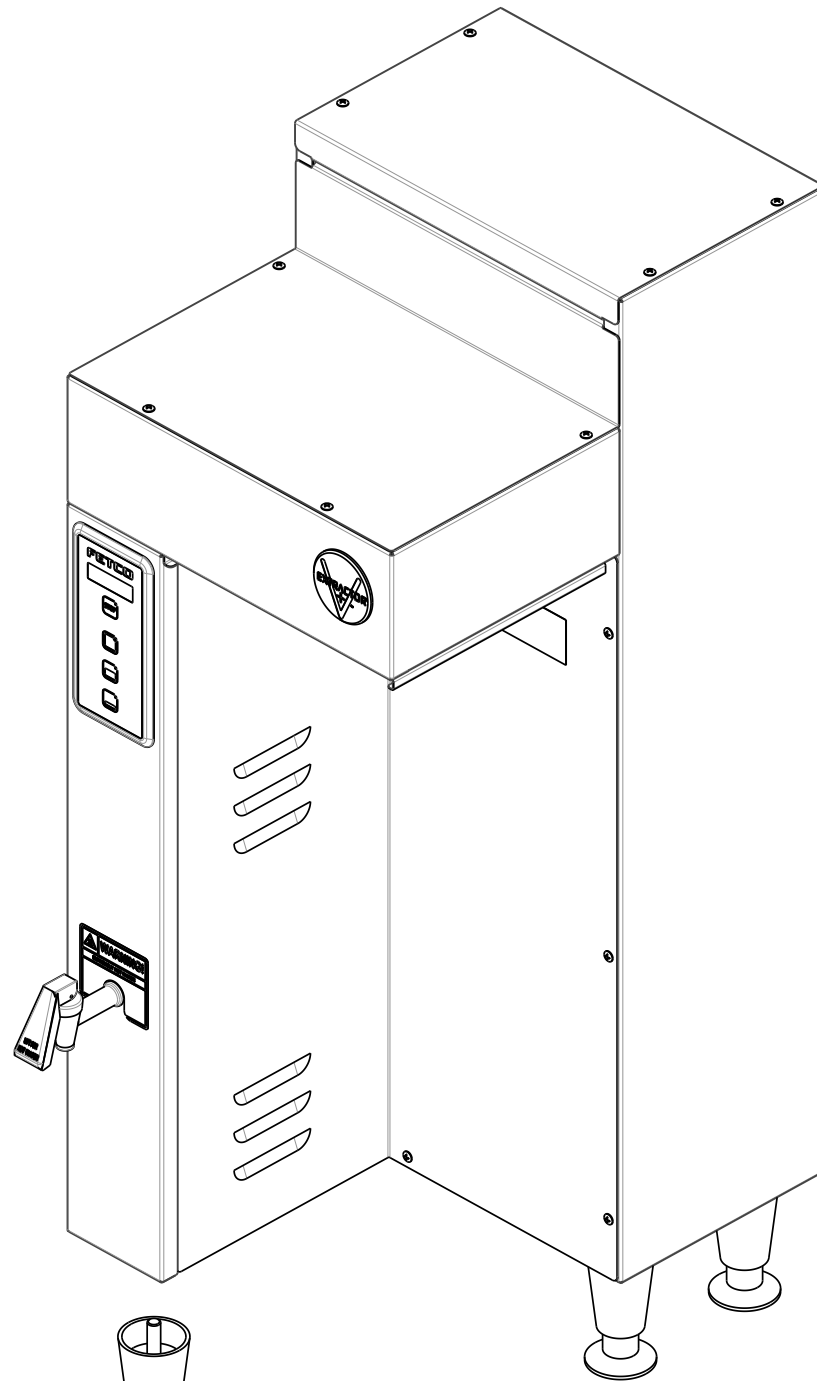
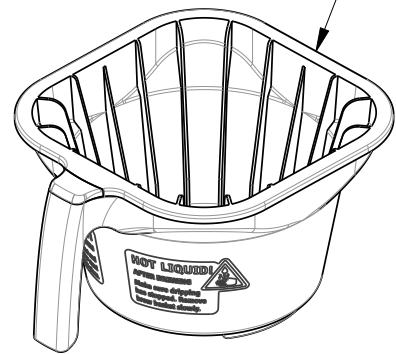

1401.00154.00  
 WIRING, CBS-1151 XV+  
 LI, N+GND, 2 HEATERS, EXPORT



4X 1073.00007.00  
 LEG, FLANGE FOOT,  
 4" HIGH

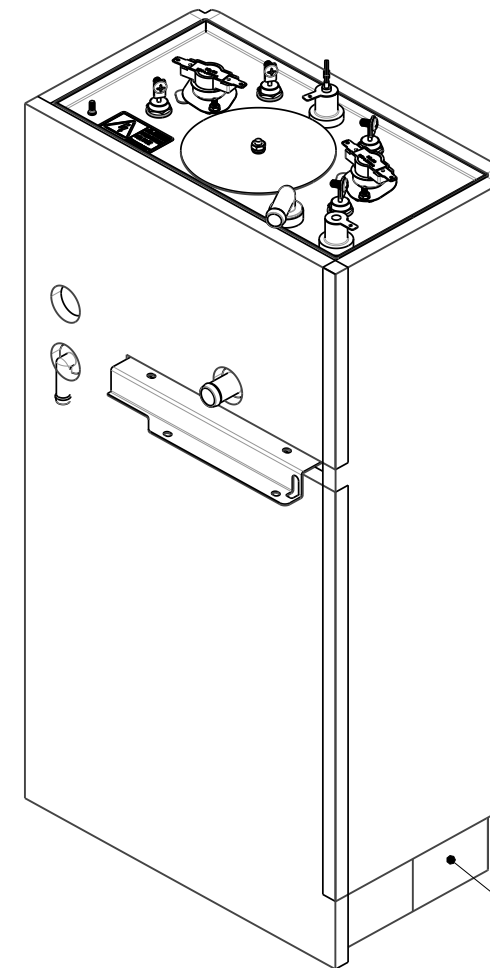

1104.00096.01  
 TANK ASSEMBLY, CBS-1151 XV+  
 2 x 2.3kW/240VAC



1086.00008.00  
 CONNECTING CLAMP

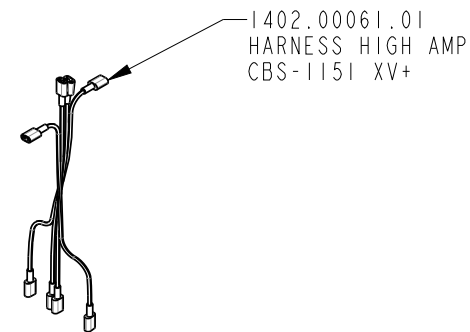

1402.00061.01  
 HARNESS HIGH AMP,  
 CBS-1151 XV+

**E115193 & E115193M**  
 (IDENTICAL TO 1101.00342.00 EXCEPT AS NOTED)

TOLERANCES		FETCO® FOOD EQUIPMENT TECHNOLOGIES COMPANY	
UNLESS OTHERWISE SPECIFIED		600 ROSE ROAD, LAKE ZURICH, IL 60047, USA PHONE: (800) 338-2699 FAX: (847) 719-3001 E-MAIL: engineering@fetco.com www.fetco.com	
ALL DIMENSIONS IN INCHES		DRAWING NAME: <b>CBS-1151 XV<sup>†</sup>, 1Ph, 2IG, 2 X 2.3kW/240VAC, 200-240VAC, INTL</b>	
ALL DECIMAL ± .005" ANGULAR ± 1/2°	THIRD-ANGLE	CREATED BY: DK	DATE 07/18/2016
		DRAWING BY: DK	SCALE 0.188
		APP'D BY: AG	SHEETS 11 of 11
MATERIAL N/A	GAUGE N/A	DRAWING NO. <b>E115193</b>	
		FINISH N/A	
		REVISION <b>A</b>	