

NOTES:

1. DRAWING TO BE INTERPRETED IN ACCORDANCE WITH THE CURRENT REVISION OF ASME Y14.5M.
2. TSI TO BE INTERPRETED AS THEORETICAL SHARP INTERSECTION
3. PARTS SHALL BE FREE OF ALL CONTAMINANTS INCLUDING GREASE, DIRT, MACHINING OIL AND OTHER CONTAMINANTS.
4. PARTS SHALL BE PACKAGED IN A MANNER TO PREVENT SCRATCHING, BOWING OR OTHER DAMAGE DURING SHIPMENT.
5. BOX INSERTS, USE PART No.'S. 1098.00147.00, 1098.00148.00 & 1098.00149.00
6. USER GUIDE, USE PART No. P166
7. SHIPPING BOX, USE PART No. 1098.00075.00

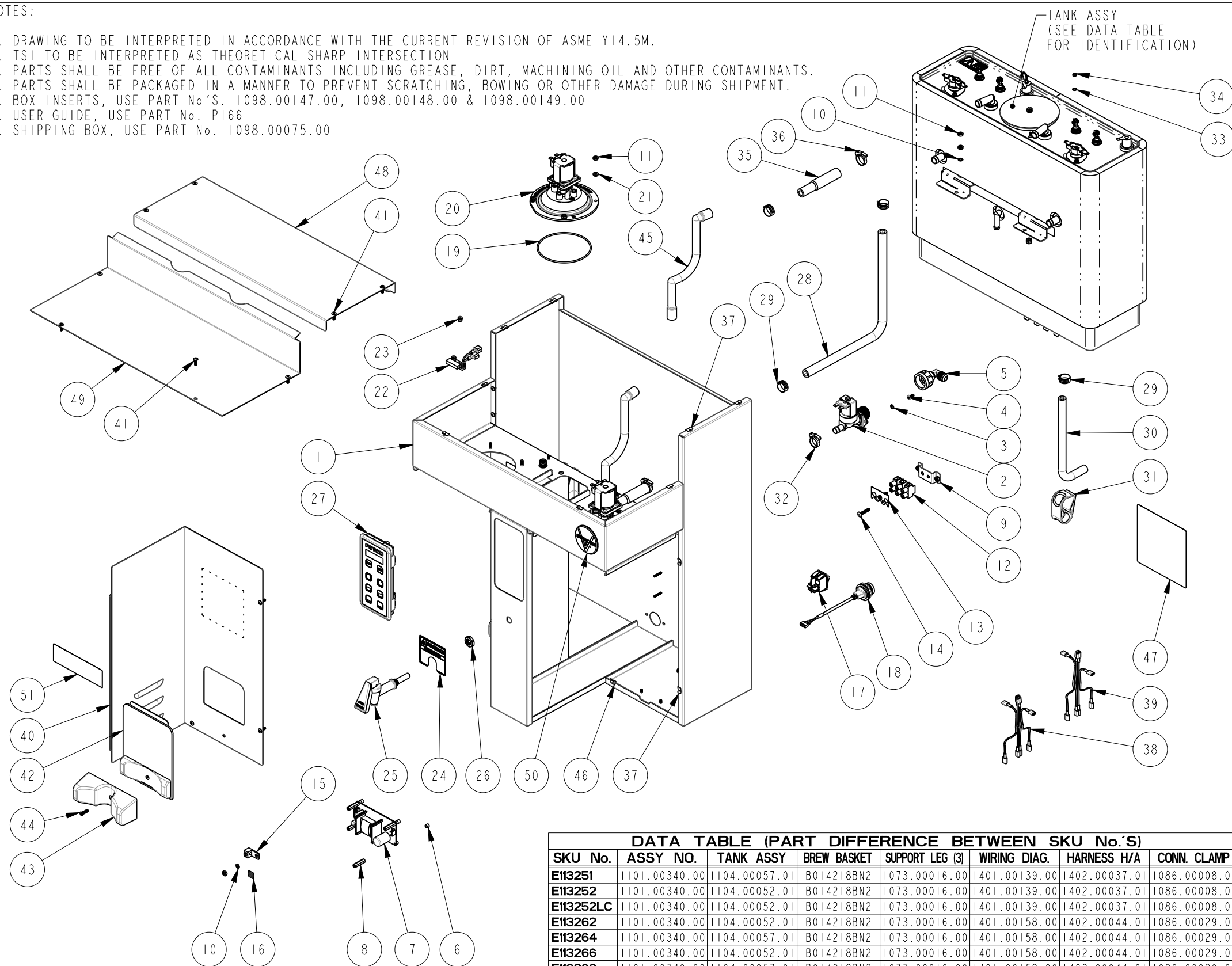

DATA TABLE (PART DIFFERENCE BETWEEN SKU No.'S)

| SKU No. | ASSY NO. | TANK ASSY | BREW BASKET | SUPPORT LEG (3) | WIRING DIAG. | HARNES H/A | CONN. CLAMP |
|-----------|---------------|---------------|-------------|-----------------|---------------|---------------|---------------|
| E113251 | 1101.00340.00 | 1104.00057.01 | B014218BN2 | 1073.00016.00 | 1401.00139.00 | 1402.00037.01 | 1086.00008.00 |
| E113252 | 1101.00340.00 | 1104.00052.01 | B014218BN2 | 1073.00016.00 | 1401.00139.00 | 1402.00037.01 | 1086.00008.00 |
| E113252LC | 1101.00340.00 | 1104.00052.01 | B014218BN2 | 1073.00016.00 | 1401.00139.00 | 1402.00037.01 | 1086.00008.00 |
| E113262 | 1101.00340.00 | 1104.00052.01 | B014218BN2 | 1073.00016.00 | 1401.00158.00 | 1402.00044.01 | 1086.00029.00 |
| E113264 | 1101.00340.00 | 1104.00057.01 | B014218BN2 | 1073.00016.00 | 1401.00158.00 | 1402.00044.01 | 1086.00029.00 |
| E113266 | 1101.00340.00 | 1104.00052.01 | B014218BN2 | 1073.00016.00 | 1401.00158.00 | 1402.00044.01 | 1086.00029.00 |
| E113268 | 1101.00340.00 | 1104.00057.01 | B014218BN2 | 1073.00016.00 | 1401.00158.00 | 1402.00044.01 | 1086.00029.00 |
| E113291 | 1101.00340.00 | 1104.00052.01 | B014218BN2 | 1073.00016.00 | 1401.00149.00 | 1402.00037.01 | 1086.00029.00 |
| E113292 | 1101.00340.00 | 1104.00057.01 | B014218BN2 | 1073.00016.00 | 1401.00149.00 | 1402.00037.01 | 1086.00008.00 |
| E113251M | 1101.00340.00 | 1104.00057.01 | B003218B1 | 1073.00016.00 | 1401.00139.00 | 1402.00037.01 | 1086.00008.00 |
| E113252M | 1101.00340.00 | 1104.00052.01 | B003218B1 | 1073.00016.00 | 1401.00139.00 | 1402.00037.01 | 1086.00008.00 |
| E113262M | 1101.00340.00 | 1104.00052.01 | B003218B1 | 1073.00016.00 | 1401.00158.00 | 1402.00044.01 | 1086.00029.00 |
| E113264M | 1101.00340.00 | 1104.00057.01 | B003218B1 | 1073.00016.00 | 1401.00158.00 | 1402.00044.01 | 1086.00029.00 |
| E113266M | 1101.00340.00 | 1104.00052.01 | B003218B1 | 1073.00016.00 | 1401.00158.00 | 1402.00044.01 | 1086.00029.00 |
| E113268M | 1101.00340.00 | 1104.00057.01 | B003218B1 | 1073.00016.00 | 1401.00158.00 | 1402.00044.01 | 1086.00029.00 |
| E113291M | 1101.00340.00 | 1104.00052.01 | B003218B1 | 1073.00016.00 | 1401.00149.00 | 1402.00037.01 | 1086.00029.00 |
| E113292M | 1101.00340.00 | 1104.00057.01 | B003218B1 | 1073.00016.00 | 1401.00149.00 | 1402.00037.01 | 1086.00008.00 |

| REVISIONS | | | | |
|-----------|------------|--------|-------------|-----|
| REV | DATE | ECO NO | DESCRIPTION | BY: |
| A | 06/27/2016 | N/A | ORIGINAL | DK |

| | | | |
|----|----|---------------|---|
| 51 | 1 | 1046.00003.00 | LABEL, CSD WARNING, 1.5" X 5.0" |
| 50 | 1 | 1041.00031.00 | LABEL, EXTRACTOR V+ LOGO |
| 49 | 1 | 1001.00347.00 | COVER, UPPER BASE, CBS-1132 EXTRACTOR V+ |
| 48 | 1 | 1001.00346.00 | COVER TOP, CBS-1132 EXTRACTOR V+ |
| 47 | 1 | 1046.00035.00 | LABEL, WARNING "TO REDUCE RISK OF ELECTRIC SHOCK OR FIRE" |
| 46 | 1 | 1084.00024.00 | NUT, CLIP ON (J-NUT), #6-32, 1050 SPR. STL. |
| 45 | 2 | 1024.00098.00 | VENT TUBE, XTS AND 11XX |
| 44 | 2 | 1082.00058.00 | SCREW, # 8-32 X 5/8, FLAT HD, PH, 18-8 SS |
| 43 | 2 | 1023.00221.00 | ADAPTER FOR AIRPOT, GRAY, CBS-2130 |
| 42 | 2 | 1102.00259.00 | LOCATOR ASSEMBLY, L3S-10, GRAY, CBS-2130 |
| 41 | 11 | 1082.00017.00 | SCREW, TRUSS HD. PHIL. MACHINE, # 6-32 X 1/2 LG. |
| 40 | 1 | 1112.00461.00 | WELDMENT, RIGHT COVER, CBS-1130 XV+ |
| 39 | 1 | 1402.00098.02 | HARNES ADDITION, LOW AMP, CBS-1132-XV+, UL |
| 38 | 1 | 1402.00098.01 | HARNES, LOW AMP, CBS-1131 XV+, UL |
| 37 | 10 | 1084.00011.00 | NUT, CLIP ON (J-NUT), #6-32, 22-20 GA., BLK-PH FINISH |
| 36 | 2 | 1086.00002.00 | CLAMP, HOSE, SIZE "G" NYLON |
| 35 | 2 | 1024.00065.00 | CONNECTOR, SILICONE, TANK TO BREW VALVE |
| 34 | 1 | 1084.00010.00 | NUT, HEX, #6-32, UNDERSIZED, ZINC PLATED |
| 33 | 1 | 1083.00009.00 | WASHER, #6 SCREW, INTL TOOTH LOCKWASHER |
| 32 | 1 | 1086.00001.00 | CLAMP, HOSE, 15.0-17.2 DIA RANGE |
| 31 | 1 | 1086.00009.00 | CLAMP, 3/4" MAX TUBE OD FLOW CONTROL |
| 30 | 1 | 1025.00071.00 | TUBE, 9/16"OD x 5/16"ID x 16.75"LG. |
| 29 | 5 | 1086.00003.00 | UNICLAMP, 15.9 HOSE OD CLAMP |
| 28 | 1 | 1025.00028.00 | TUBE, 5/8"OD X 3/8"ID X 13.25"LG, HOT WATER VALVE, IN |
| 27 | 1 | 1102.00372.00 | ASSEMBLY, FRONT PANEL, CBS-1100 DUAL |
| 26 | 1 | 1084.00048.00 | JAM NUT, 1/2-20 UNF, NICKEL PLATED BRASS |
| 25 | 1 | 1071.00055.00 | FAUCET, HOT WATER, PSC-BR-8, WITH FLAT AND STEM |
| 24 | 1 | 1046.00051.00 | LABEL, "WARNING, EXTREMELY HOT WATER" |
| 23 | 4 | 1029.00006.00 | NUT, FINGER, #4-40 NYLON |
| 22 | 2 | 1102.00113.00 | SWITCH, REED, ASSEMBLY |
| 21 | 8 | 1083.00010.00 | WASHER, #10 SCREW W/NEOPRENE-BONDED SEAL |
| 20 | 2 | 1102.00203.01 | SPRAY HEAD, SMALL, NO VENT, ASSEMBLY |
| 19 | 2 | 1024.00063.00 | O-RING, 3 15/16" x 3/32" CS, DASH # 154, BUNA-N, DURO-A50 |
| 18 | 1 | 1058.00055.00 | USB CONNECTOR |
| 17 | 1 | 1058.00024.00 | SWITCH, POWER, DOUBLE POLE, 16A, 125/250 VAC |
| 16 | 1 | 1044.00012.00 | LABEL GROUND, CE |
| 15 | 1 | 1065.00009.00 | GROUND LUG CONNECTOR, 14-2 AWG, ALUMINUM |
| 14 | 2 | 1082.00082.00 | SCREW, PHILLIP HD., 8-32 THREAD |
| 13 | 1 | 1052.00025.00 | PLATE, MARKING #BS1016E |
| 12 | 1 | 1052.00022.00 | EUROSTRIP HE10 TERMINAL BLOCK., 3 POLE, 50AMP, 18-8 |
| 11 | 15 | 1084.00006.00 | NUT, 8-32 18-8 HEX MACHINE SCREW |
| 10 | 5 | 1083.00011.00 | WASHER, #8 SCREW SIZE, INTERNAL TOOTH LOCK |
| 9 | 1 | 1112.00246.00 | WELDMENT BRACKET TERMINAL BLOCK, 3 POLE |
| 8 | 4 | 1029.00012.00 | SPACER, 25" HEX X 1" LG, FEM #4-40 THREAD |
| 7 | 1 | 1052.00001.00 | POWER SUPPLY, 90-264VAC/24VDC, 1.8A |
| 6 | 8 | 1081.00006.00 | SPACER, 6MM OD x 3.2MM ID x 5MM LG, Z/P |
| 5 | 1 | 1102.00243.00 | ADAPTER ASSY, 3/4" BSP x 1/4" NPT x 3/8" TUBE |
| 4 | 2 | 1082.00010.00 | SCREW, M4x10 ZINC-PLATED PAN HD. PHILLIPS MACH. |
| 3 | 2 | 1083.00005.00 | WASHER, M4 18-8 INTERNAL TOOTH LOCKWASHER |
| 2 | 1 | 1057.00043.00 | SOLENOID VALVE, 5.5L/min, 180 DEG, 24VDC |
| 1 | 1 | 1111.00085.00 | WELDMENT BODY, CBS-1132 XV+ |

| ITEM NO | QTY | PART NO | DESCRIPTION |
|----------------------------|-----|---------|-------------|
| BILL OF MATERIALS | | | |
| TOLERANCES | | | |
| UNLESS OTHERWISE SPECIFIED | | | |
| ALL DIMENSIONS IN INCHES | | | |
| DECIMAL ± .005" | | | |
| ANGULAR ± 1/2° | | | |
| THIRD-ANGLE | | | |
| MATERIAL | | | |
| N/A | | | |
| GAUGE | | | |
| N/A | | | |
| FINISH | | | |
| N/A | | | |

FETCO FOOD EQUIPMENT TECHNOLOGIES COMPANY
 600 ROSE ROAD, LAKE ZURICH, IL 60047, USA
 PHONE: (800) 338-2699 FAX: (847) 719-3001
 E-MAIL: engineering@fetco.com www.fetco.com

DRAWING NAME:
ASSEMBLY, CBS-1132 XV+, COMMON

| | | |
|---------------------------|---------------------|-----------------------|
| CREATED BY: DK | DATE: 06/27/2016 | DRAWING NO.: |
| DRAWING BY: E. FORONDA | SCALE: 0.125 | 1101.00340.00 |
| APP'D BY: AG | SHEETS: 1 of 11 | REVISION: A |

PROPRIETARY AND CONFIDENTIAL. THE INFORMATION CONTAINED IN THIS DRAWING IS THE SOLE PROPERTY OF FETCO. ANY REPRODUCTION IN PART OR AS A WHOLE WITHOUT THE WRITTEN PERMISSION OF FETCO IS PROHIBITED.

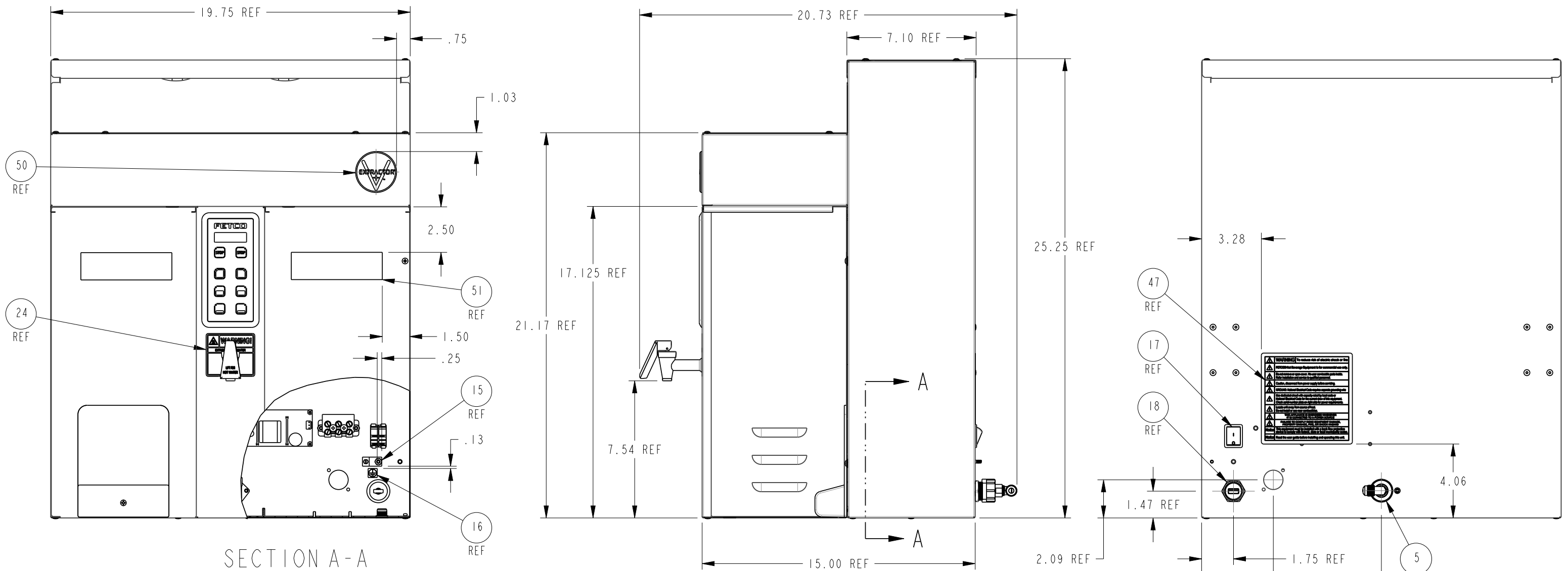

SECTION A-A

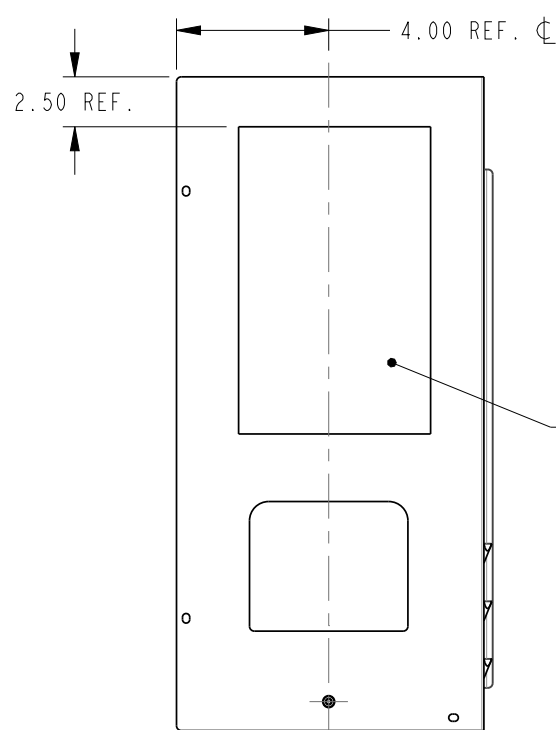

POSITION LABELS AS SHOWN

SCHEMATIC ON THE BACK OF ITEM 41,
1112.00461.00

PROPRIETARY AND CONFIDENTIAL.
THE INFORMATION CONTAINED IN THIS DRAWING IS THE SOLE PROPERTY OF FETCO.
ANY REPRODUCTION IN PART OR AS A WHOLE WITHOUT THE WRITTEN PERMISSION OF FETCO IS PROHIBITED.

| TOLERANCES | | |
|---|------------|---------------|
| UNLESS OTHERWISE SPECIFIED | | |
| ALL DIMENSIONS IN INCHES | | |
| ALL DECIMAL $\pm .005"$ ANGULAR $\pm 1/2^\circ$ | | |
| THIRD-ANGLE | | |
| | | |
| MATERIAL | | |
| N/A | | |
| GAUGE | | |
| N/A | | |
| FINISH | | |
| N/A | | |
| FETCO FOOD EQUIPMENT TECHNOLOGIES COMPANY 600 ROSE ROAD, LAKE ZURICH, IL 60047, USA PHONE: (800) 338-2699 FAX: (847) 719-3001 E-MAIL: engineering@fetco.com www.fetco.com | | |
| DRAWING NAME: | | |
| ASSEMBLY, CBS-1132 XV⁺, COMMON | | |
| CREATED BY: | DATE | DRAWING NO. |
| DK | 06/27/2016 | 1101.00340.00 |
| DRAWING BY: | SCALE | REVISION |
| E. FORONDA | 0.188 | A |
| APP'D BY: | SHEETS | |
| AG | 2 of 11 | |

| REVISIONS | | | | |
|-----------|------------|--------|-------------|-----|
| REV | DATE | ECO NO | DESCRIPTION | BY: |
| A | 06/27/2016 | N/A | ORIGINAL | DK |

A

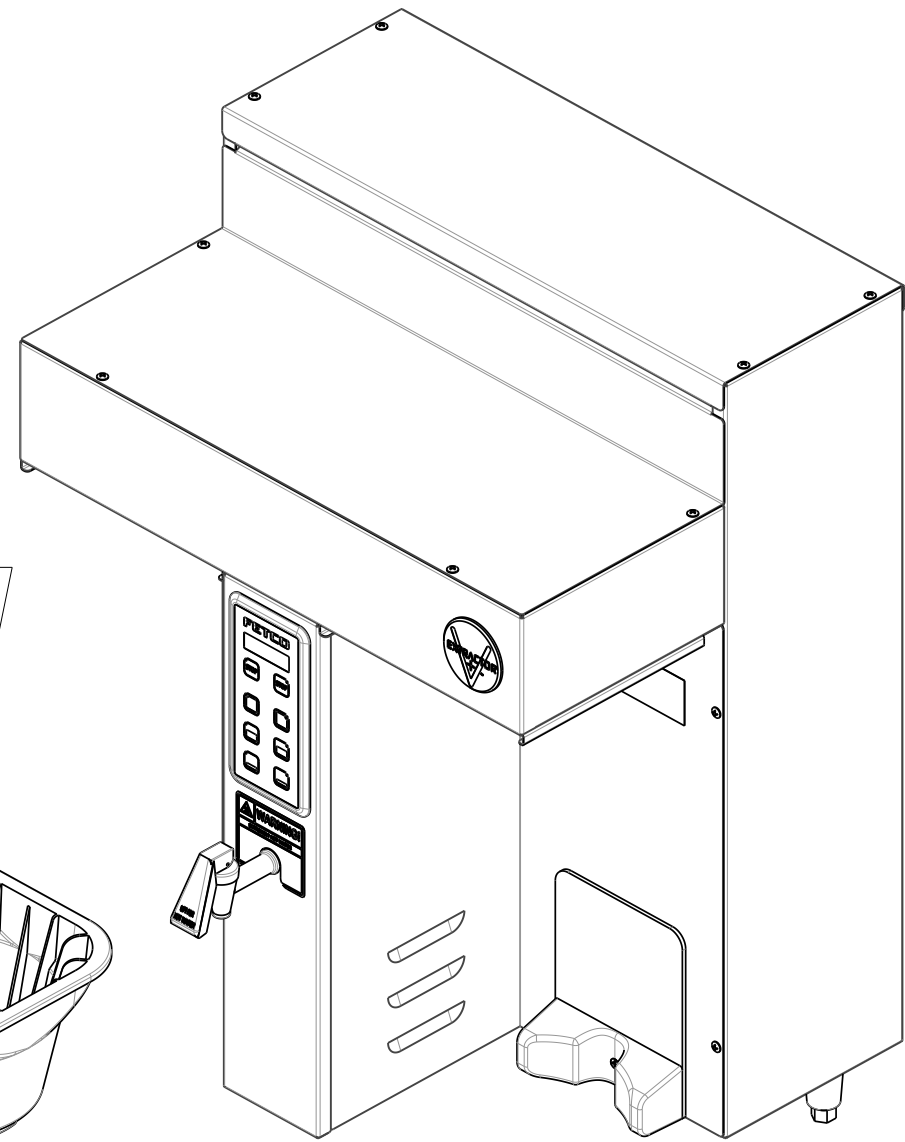

SKU # E113251 - 2X B014218BN2 (BROWN PLUG)
 SKU # E113251M - 2X B003218B1 (BLACK HANDLE)
 BB ASSY, 13" X 5", Ø.218" HOLE

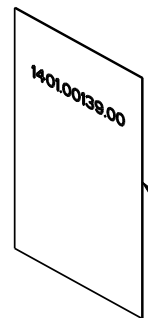
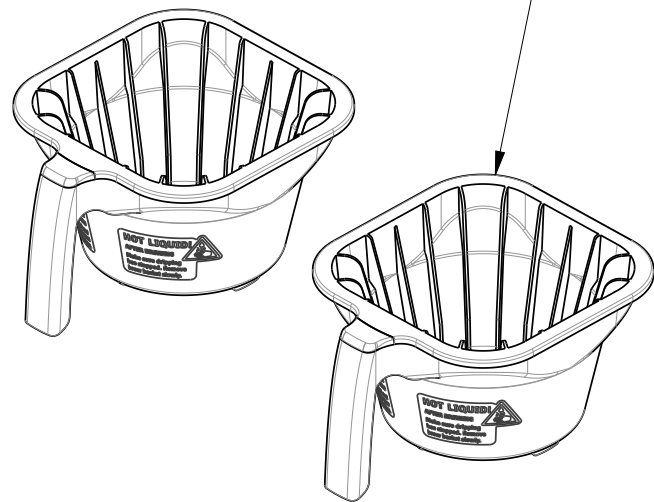

1401.00139.00
 WIRING, CBS-1132 XV+,
 (L1, L2+GND), 2 HEATERS, UL



3X 1073.00016.00
 LEG, THERMOPLASTIC,
 2.50" (63mm)

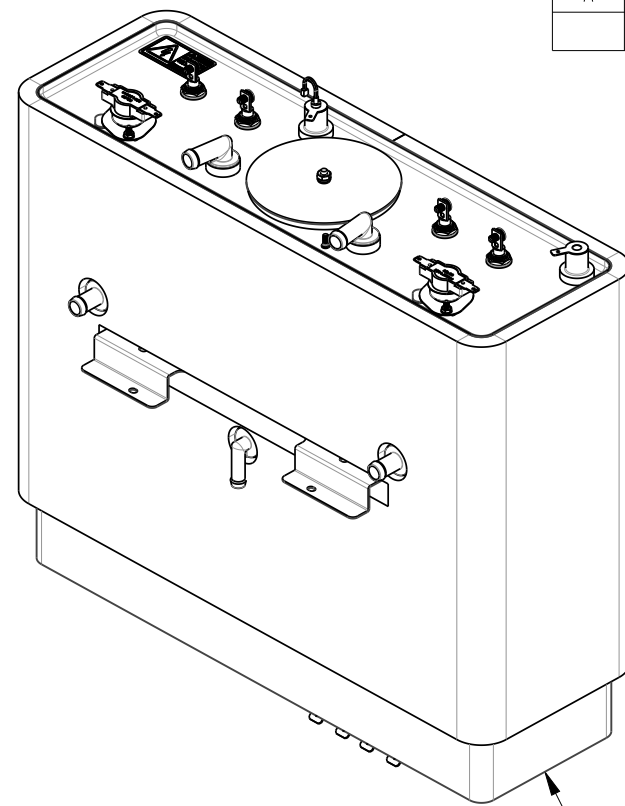

1086.00008.00
 CONNECTOR CLAMP

1104.00057.01
 TANK ASSEMBLY, CBS-1132 XV+
 2 x 2.3kW/240VAC

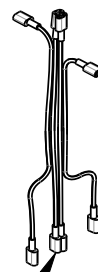

1402.00037.01
 HARNESS HIGH AMP,
 CBS-1132 XV+

E113251 & E113251M
 (IDENTICAL TO 1101.00340.00 EXCEPT AS NOTED)

| TOLERANCES | | FETCO® FOOD EQUIPMENT TECHNOLOGIES COMPANY | | |
|---------------------------------------|--|---|--------------------|-------------------------------|
| UNLESS OTHERWISE SPECIFIED | | 600 ROSE ROAD, LAKE ZURICH, IL 60047, USA PHONE: (800) 338-2699 FAX: (847) 719-3001 E-MAIL: engineering@fetco.com www.fetco.com | | |
| ALL DIMENSIONS IN INCHES | | DRAWING NAME: CBS-1132 XV†, 1Ph, 2IG, 2 X 2.3kW/240VAC, 200-240VAC, | | |
| ALL DECIMAL ± .005" ANGULAR ± 1/2° | | CREATED BY: DK | DATE 06/27/2016 | DRAWING NO. E113251 |
| THIRD-ANGLE | | DRAWING BY: E. FORONDA | SCALE 0.188 | REVISION A |
| MATERIAL N/A | | APP'D BY: AG | SHEETS 3 of 11 | FINISH N/A |
| | | GAUGE N/A | | |

| REVISIONS | | | | |
|-----------|------------|--------|-------------|-----|
| REV | DATE | ECO NO | DESCRIPTION | BY: |
| A | 06/27/2016 | N/A | ORIGINAL | DK |

A

SKU # E113252 - 2X B014218BN2 (BROWN PLUG)
 SKU # E113252M - 2X B003218B1 (BLACK HANDLE)
 BB ASSY, 13" X 5", Ø.218" HOLE

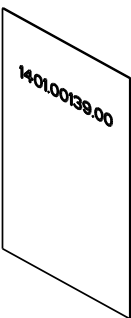
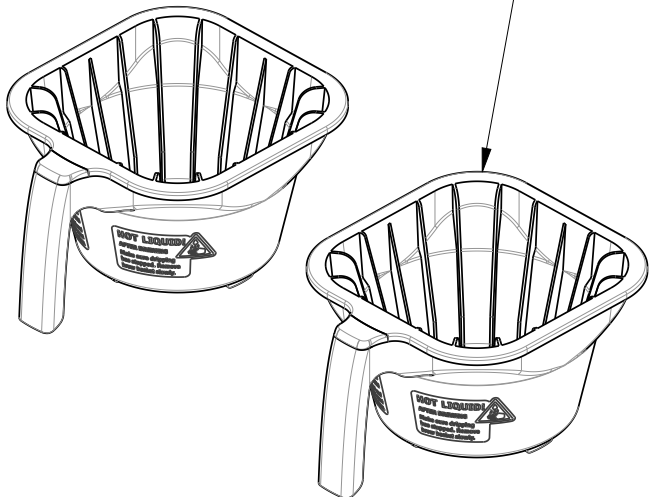

1401.00139.00
 WIRING, CBS-1132 XV+,
 (L1, L2+GND), 2 HEATERS, UL



3X 1073.00016.00
 LEG, THERMOPLASTIC,
 2.50" (63mm)

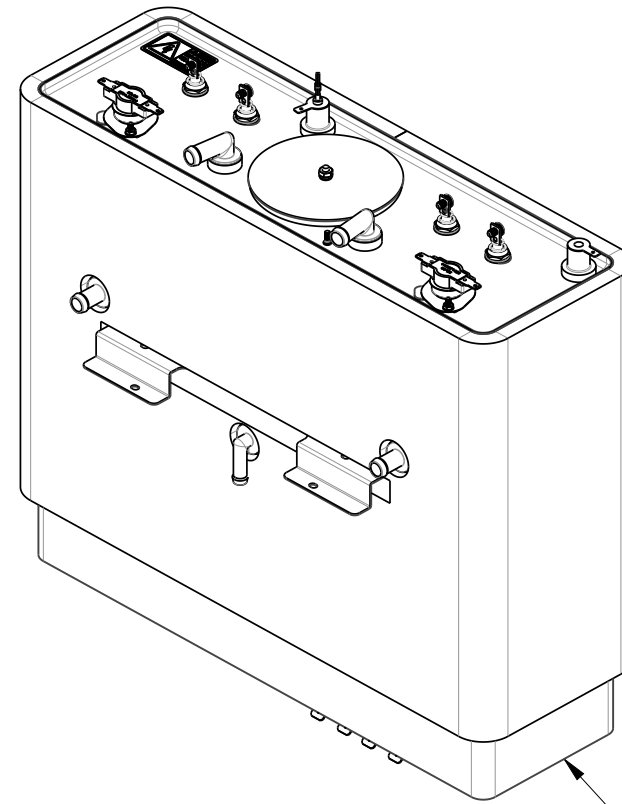
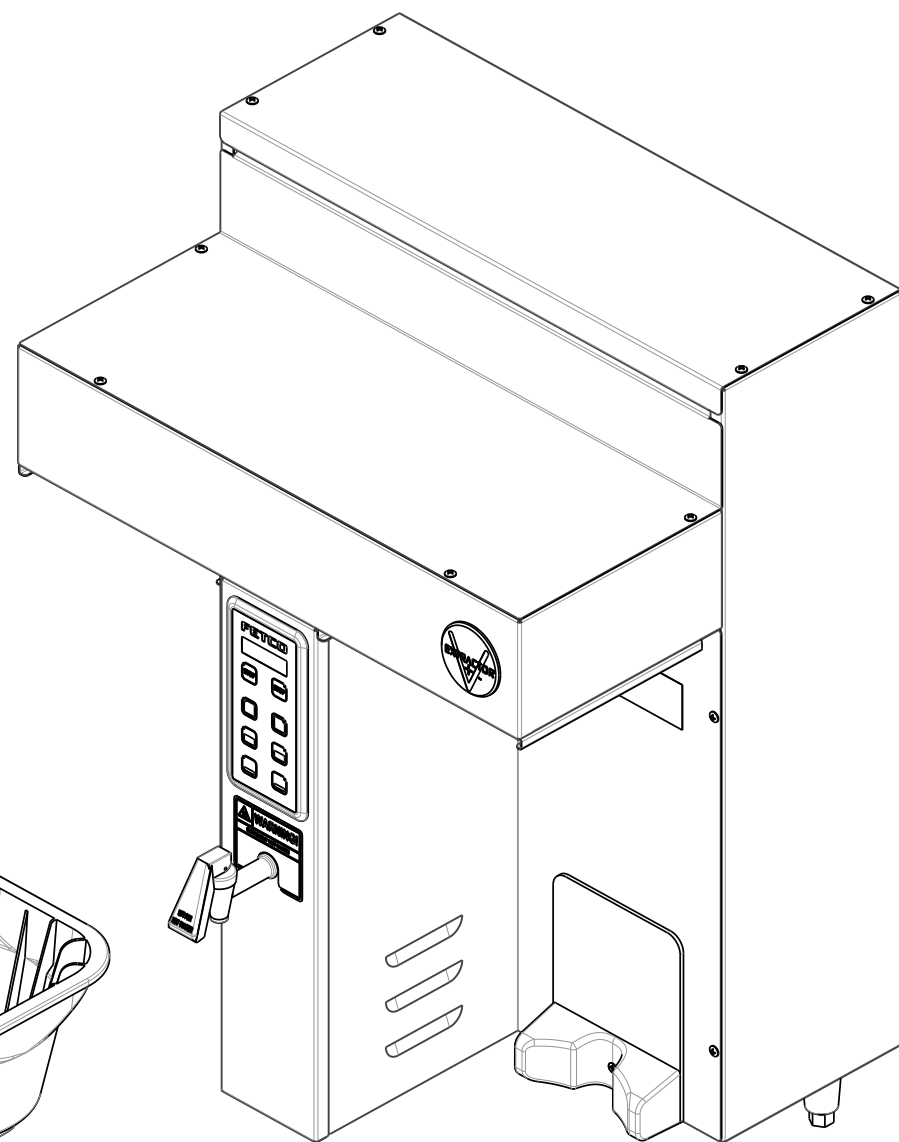

1086.00008.00
 CONNECTOR CLAMP

1104.00052.01
 TANK ASSEMBLY, CBS-1132 XV+
 2 x 3kW/240VAC

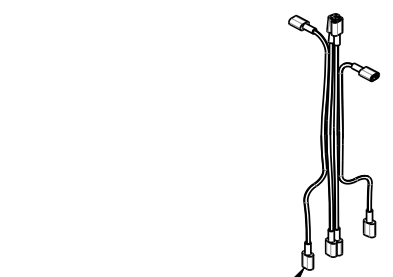

1402.00037.01
 HARNESS HIGH AMP,
 CBS-1132 XV+

E113252 & E113252M
 (IDENTICAL TO 1101.00340.00 EXCEPT AS NOTED)

PROPRIETARY AND CONFIDENTIAL.
 THE INFORMATION CONTAINED IN THIS DRAWING IS THE SOLE PROPERTY OF FETCO.
 ANY REPRODUCTION IN PART OR AS A WHOLE WITHOUT THE WRITTEN PERMISSION OF FETCO IS PROHIBITED.

| TOLERANCES | | FETCO® FOOD EQUIPMENT TECHNOLOGIES COMPANY | |
|---------------------------------------|--------------|---|--------------------|
| UNLESS OTHERWISE SPECIFIED | | 600 ROSE ROAD, LAKE ZURICH, IL 60047, USA PHONE: (800) 338-2699 FAX: (847) 719-3001 E-MAIL: engineering@fetco.com www.fetco.com | |
| ALL DIMENSIONS IN INCHES | | DRAWING NAME: CBS-1132 XV†, 1Ph, 2†G, 2 X 3kW/240VAC, 200-240VAC | |
| ALL DECIMAL ± .005" ANGULAR ± 1/2° | THIRD-ANGLE | CREATED BY: DK | DATE 06/27/2016 |
| | | DRAWING BY: E. FORONDA | SCALE 0.188 |
| | | APP'D BY: AG | SHEETS 4 of 11 |
| MATERIAL N/A | GAUGE N/A | DRAWING NO. E113252 | |
| | | FINISH N/A | |
| | | REVISION A | |

| REVISIONS | | | | |
|-----------|------------|--------|-------------|-----|
| REV | DATE | ECO NO | DESCRIPTION | BY: |
| A | 06/27/2016 | N/A | ORIGINAL | DK |

A

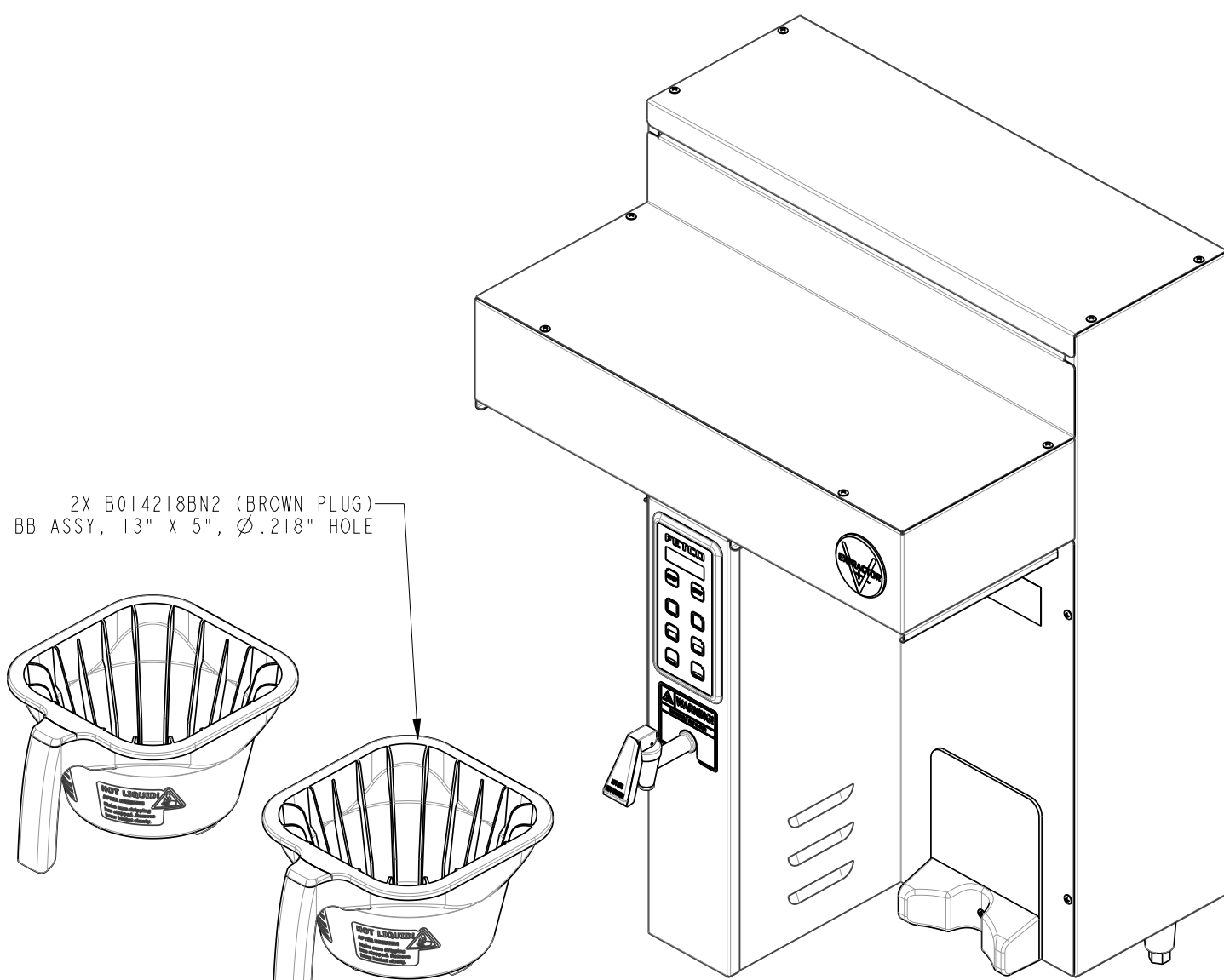

2X B014218BN2 (BROWN PLUG)
BB ASSY, 13" X 5", Ø.218" HOLE

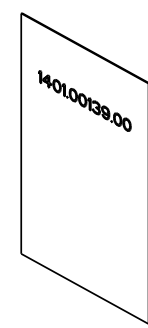
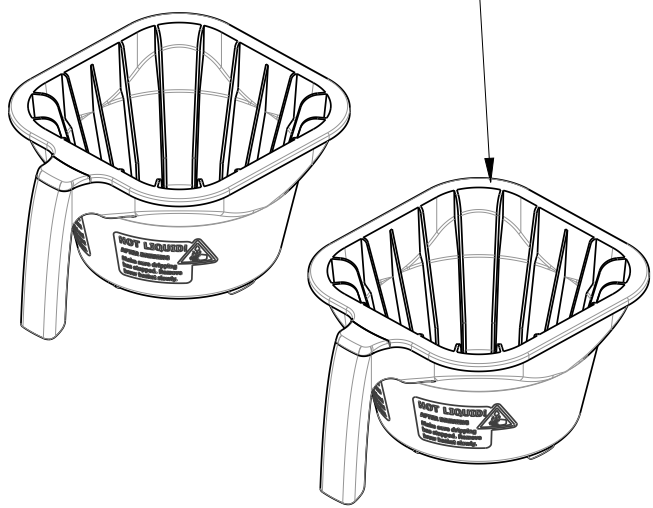

1401.00139.00
WIRING, CBS-1132 XV+,
(L1, L2+GND), 2 HEATERS, UL



3X 1073.00016.00
LEG, THERMOPLASTIC,
2.50" (63mm)

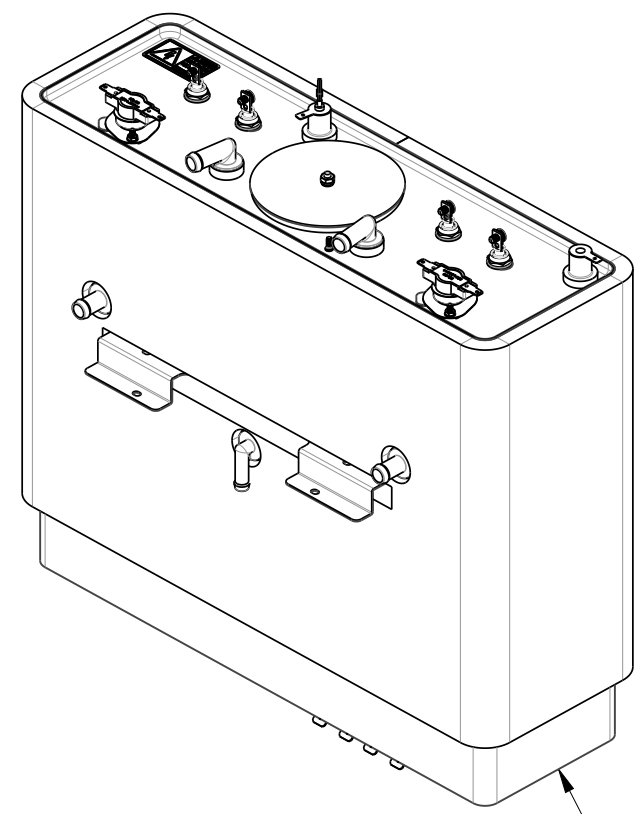

1086.00008.00
CONNECTOR CLAMP

1104.00052.01
TANK ASSEMBLY, CBS-1132 XV+
2 x 3kW/240VAC

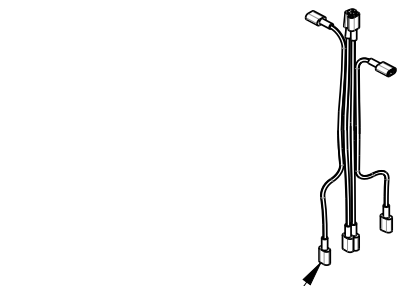

1402.00037.01
HARNESS HIGH AMP,
CBS-1132 XV+

E113252LC
(IDENTICAL TO 1101.00340.00 EXCEPT AS NOTED)

PROPRIETARY AND CONFIDENTIAL.
THE INFORMATION CONTAINED IN THIS DRAWING IS THE SOLE PROPERTY OF FETCO.
ANY REPRODUCTION IN PART OR AS A WHOLE WITHOUT THE WRITTEN PERMISSION OF FETCO IS PROHIBITED.

| TOLERANCES | | FETCO® FOOD EQUIPMENT TECHNOLOGIES COMPANY | | |
|---------------------------------------|--|---|--------------------|---------------------------------|
| UNLESS OTHERWISE SPECIFIED | | 600 ROSE ROAD, LAKE ZURICH, IL 60047, USA PHONE: (800) 338-2699 FAX: (847) 719-3001 E-MAIL: engineering@fetco.com www.fetco.com | | |
| ALL DIMENSIONS IN INCHES | | DRAWING NAME: CBS-1132 XV+, 1Ph, 2IG, 2 X 3kW/240VAC, 200-240VAC, LA COLOMBE | | |
| ALL DECIMAL ± .005" ANGULAR ± 1/2° | | CREATED BY: DK | DATE 06/27/2016 | DRAWING NO. E113252LC |
| THIRD-ANGLE | | DRAWING BY: E. FORONDA | SCALE 0.188 | REVISION A |
| MATERIAL N/A | | APP'D BY: AG | SHEETS 5 of 11 | FINISH N/A |
| | | GAUGE N/A | | |

| REVISIONS | | | | |
|-----------|------------|--------|-------------|-----|
| REV | DATE | ECO NO | DESCRIPTION | BY: |
| A | 06/27/2016 | N/A | ORIGINAL | DK |

A

SKU # E113292 - 2X B014218BN2 (BROWN PLUG)
 SKU # E113292M - 2X B003218B1 (BLACK HANDLE)
 BB ASSY, 13" X 5", Ø.218" HOLE

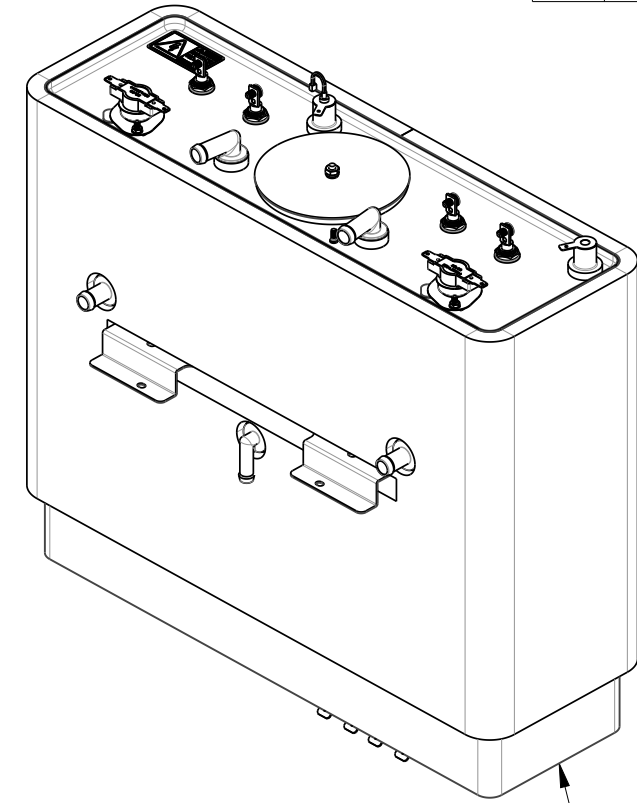
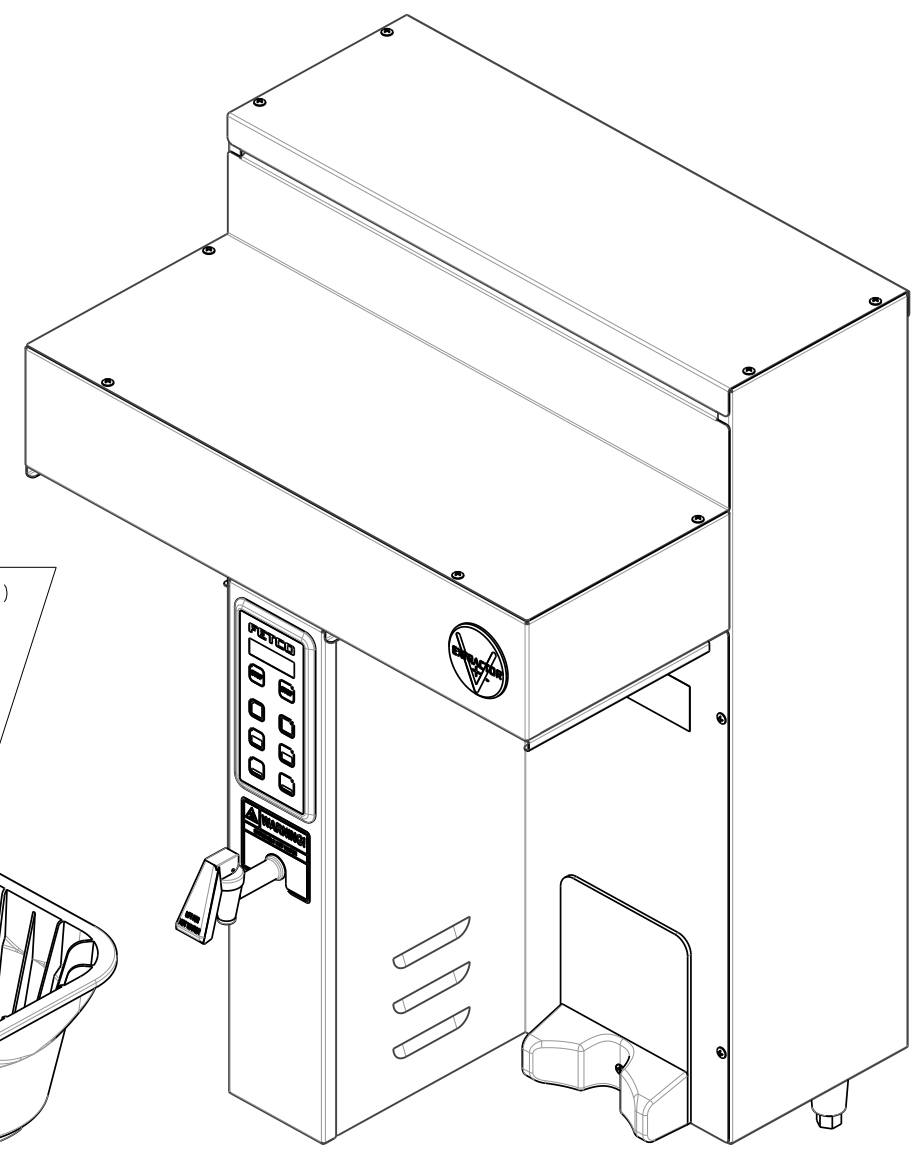
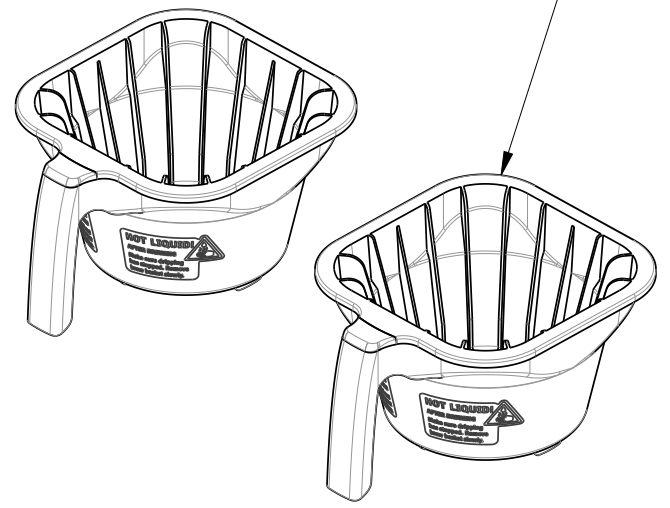

1086.00008.00
CONNECTOR CLAMP

1104.00057.01
TANK ASSEMBLY, CBS-1132 XV+
2 x 2.3kW/240VAC

1401.00149.00

1401.00149.00
WIRING, CBS-1132 XV+,
L1, N, GND, 2 HEATERS

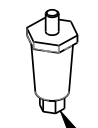

3X 1073.00016.00
LEG, THERMOPLASTIC,
2.50" (63mm)

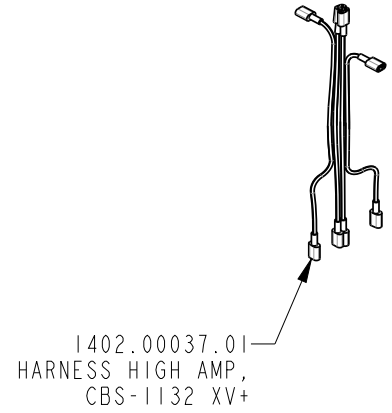

1402.00037.01
HARNESS HIGH AMP,
CBS-1132 XV+

E113292 & E113292M
 (IDENTICAL TO 1101.00340.00 EXCEPT AS NOTED)

PROPRIETARY AND CONFIDENTIAL.
 THE INFORMATION CONTAINED IN THIS DRAWING IS THE SOLE PROPERTY OF FETCO.
 ANY REPRODUCTION IN PART OR AS A WHOLE WITHOUT THE WRITTEN PERMISSION OF FETCO IS PROHIBITED.

| TOLERANCES | | FETCO® FOOD EQUIPMENT TECHNOLOGIES COMPANY | | |
|---------------------------------------|--|---|--------------------|-------------------------------|
| UNLESS OTHERWISE SPECIFIED | | 600 ROSE ROAD, LAKE ZURICH, IL 60047, USA PHONE: (800) 338-2699 FAX: (847) 719-3001 E-MAIL: engineering@fetco.com www.fetco.com | | |
| ALL DIMENSIONS IN INCHES | | DRAWING NAME: CBS-1132 XV†, 1Ph, 2IG, 2 X 2.3kW/240VAC, 220-240VAC, EXPORT | | |
| ALL DECIMAL ± .005" ANGULAR ± 1/2° | | CREATED BY: DK | DATE 06/27/2016 | DRAWING NO. E113292 |
| THIRD-ANGLE | | DRAWING BY: E. FORONDA | SCALE 0.188 | REVISION A |
| MATERIAL N/A | | APP'D BY: AG | SHEETS 6 of 11 | FINISH N/A |
| | | GAUGE N/A | | |

REVISIONS

| REV | DATE | ECO NO | DESCRIPTION | BY: | A |
|-----|------------|--------|-------------|-----|---|
| A | 06/27/2016 | N/A | ORIGINAL | DK | |

SKU # E113262 - 2X B014218BN2 (BROWN PLUG)
 SKU # E113262M - 2X B003218B1 (BLACK HANDLE)
 BB ASSY, 13" X 5", Ø.218" HOLE

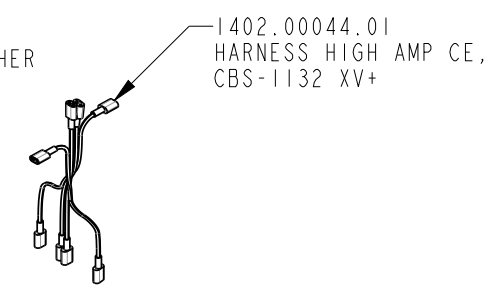
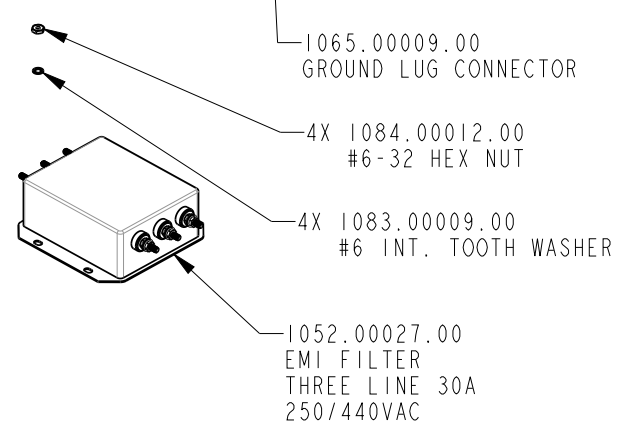
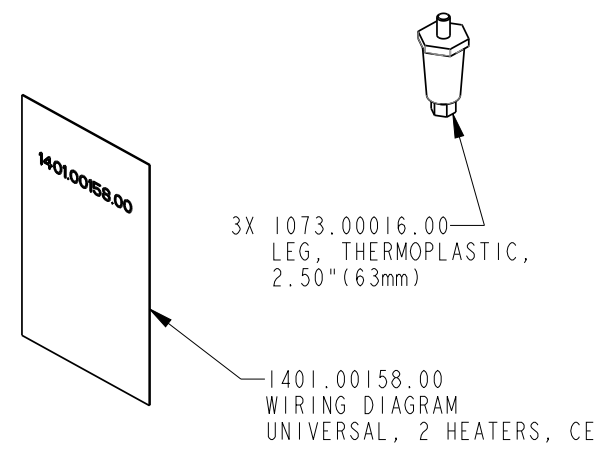
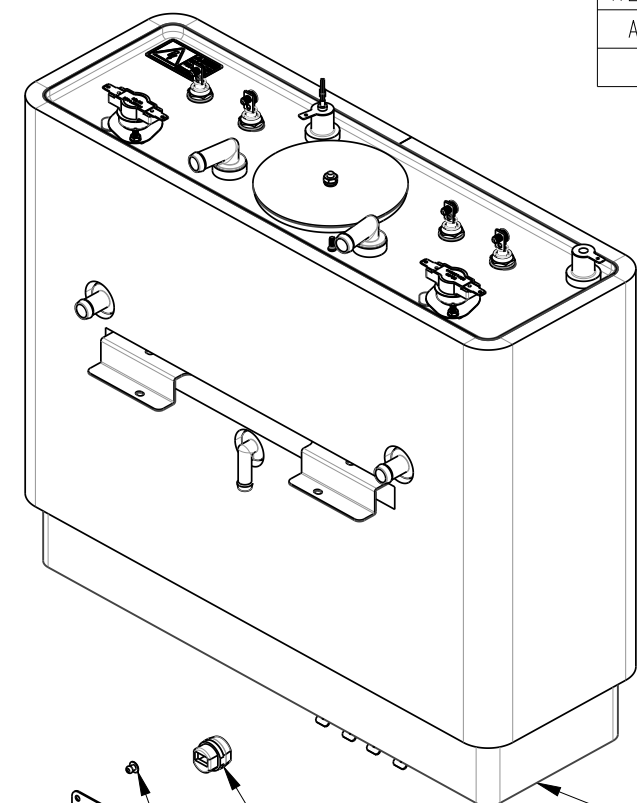
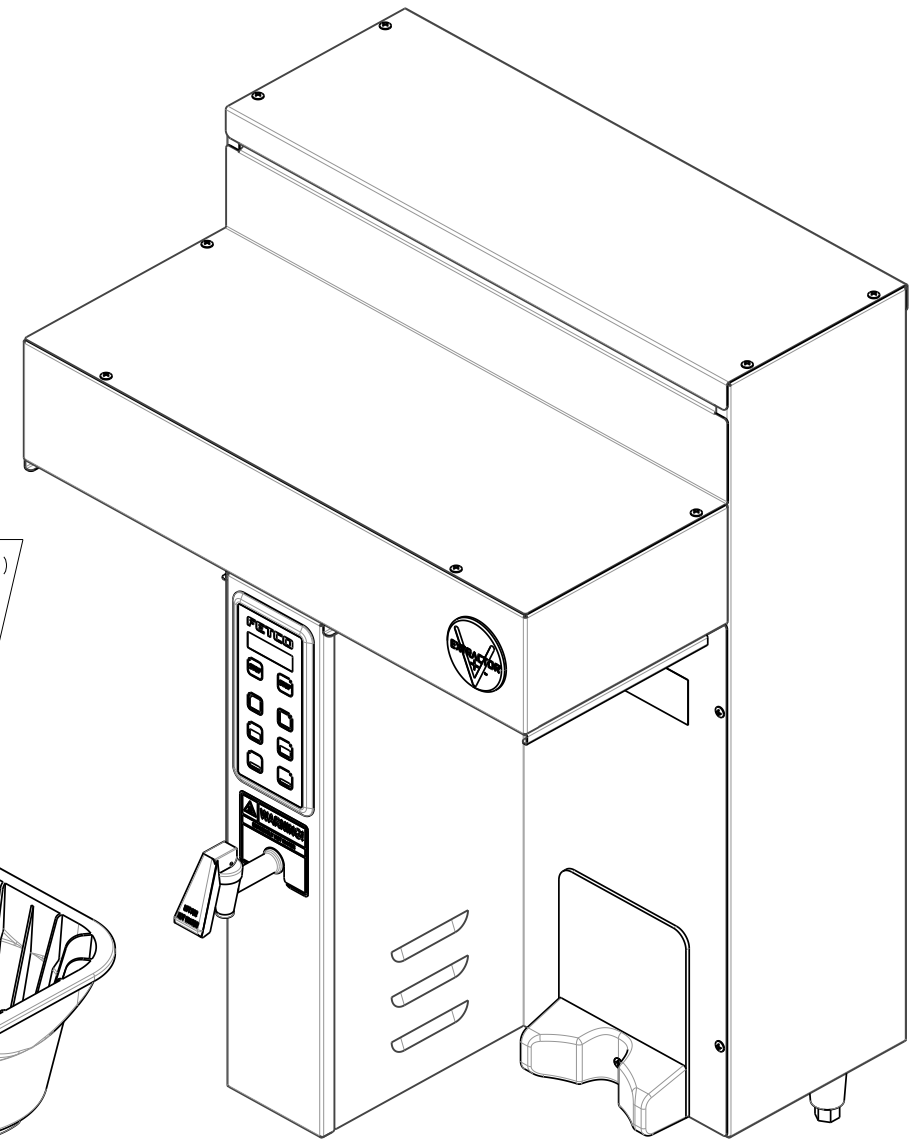
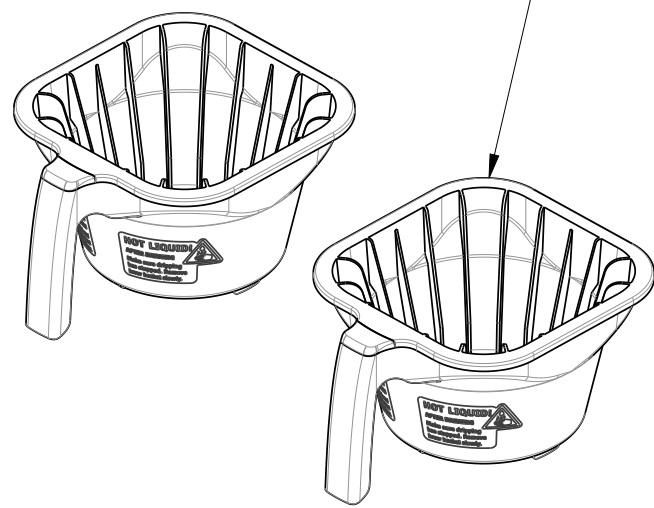

3X 1073.00016.00
 LEG, THERMOPLASTIC,
 2.50" (63mm)

1401.00158.00
 WIRING DIAGRAM
 UNIVERSAL, 2 HEATERS, CE

1086.00029.00
 CONNECTOR CLAMP

2X 1087.00002.00
 RIVET, BLIND DOMED

1003.00348.00
 ADAPTER PLATE
 STRAIN RELIEF, CE

1044.00013.00
 LABEL, EQUIPOTENTIALITY, CE

1084.00006.00
 #8-32 HEX NUT

1083.00011.00
 #8 INT. TOOTH WASHER

1065.00009.00
 GROUND LUG CONNECTOR

1104.00052.01
 TANK ASSEMBLY, CBS-1132 XV+
 2 x 3kW/240VAC

4X 1084.00012.00
 #6-32 HEX NUT

4X 1083.00009.00
 #6 INT. TOOTH WASHER

1052.00027.00
 EMI FILTER
 THREE LINE 30A
 250/440VAC

E113262 & E113262M
 (IDENTICAL TO 1101.00340.00 EXCEPT AS NOTED)

PROPRIETARY AND CONFIDENTIAL.
 THE INFORMATION CONTAINED IN THIS DRAWING IS THE SOLE PROPERTY OF FETCO.
 ANY REPRODUCTION IN PART OR AS A WHOLE WITHOUT THE WRITTEN PERMISSION OF FETCO IS PROHIBITED.

| | | | |
|--|--------------|---|--------------------|
| TOLERANCES UNLESS OTHERWISE SPECIFIED | | FETCO FOOD EQUIPMENT TECHNOLOGIES COMPANY 600 ROSE ROAD, LAKE ZURICH, IL 60047, USA PHONE: (800) 338-2699 FAX: (847) 719-3001 E-MAIL: engineering@fetco.com www.fetco.com | |
| ALL DIMENSIONS IN INCHES | | DRAWING NAME: CBS-1132 XV+, 2Ph, 2L,N,PE, 2 X 3kW/240VAC, 230/400VAC, CE | |
| ALL DECIMAL ± .005" ANGULAR ± 1/2° | THIRD-ANGLE | CREATED BY: DK | DATE 06/27/2016 |
| | | DRAWING BY: E. FORONDA | SCALE 0.188 |
| | | APP'D BY: AG | SHEETS 7 of 11 |
| MATERIAL N/A | GAUGE N/A | DRAWING NO. E113262 | |
| | | REVISION A | |
| | | FINISH N/A | |

| REVISIONS | | | | |
|-----------|------------|--------|-------------|-----|
| REV | DATE | ECO NO | DESCRIPTION | BY: |
| A | 06/27/2016 | N/A | ORIGINAL | DK |

A

SKU # E113264 - 2X B014218BN2 (BROWN PLUG)
 SKU # E113264M - 2X B003218B1 (BLACK HANDLE)
 BB ASSY, 13" X 5", Ø.218" HOLE

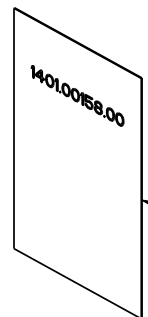
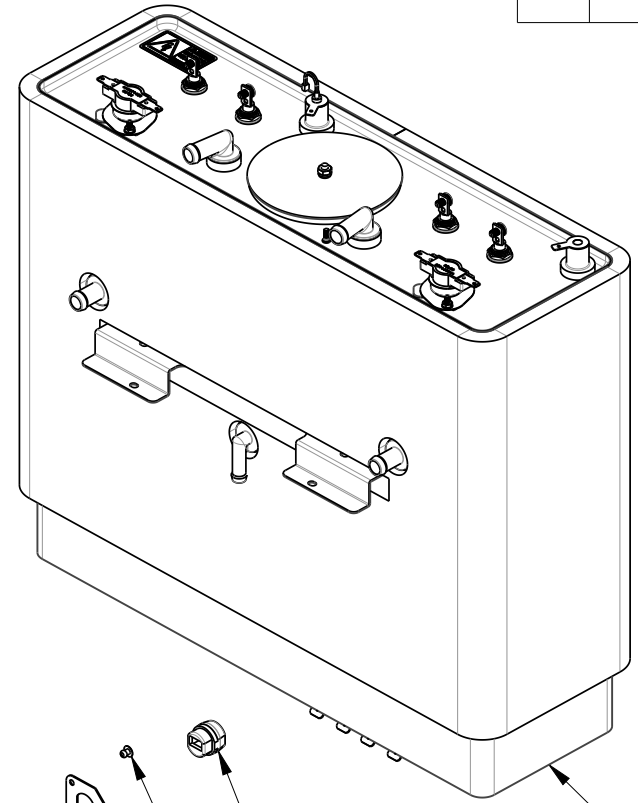
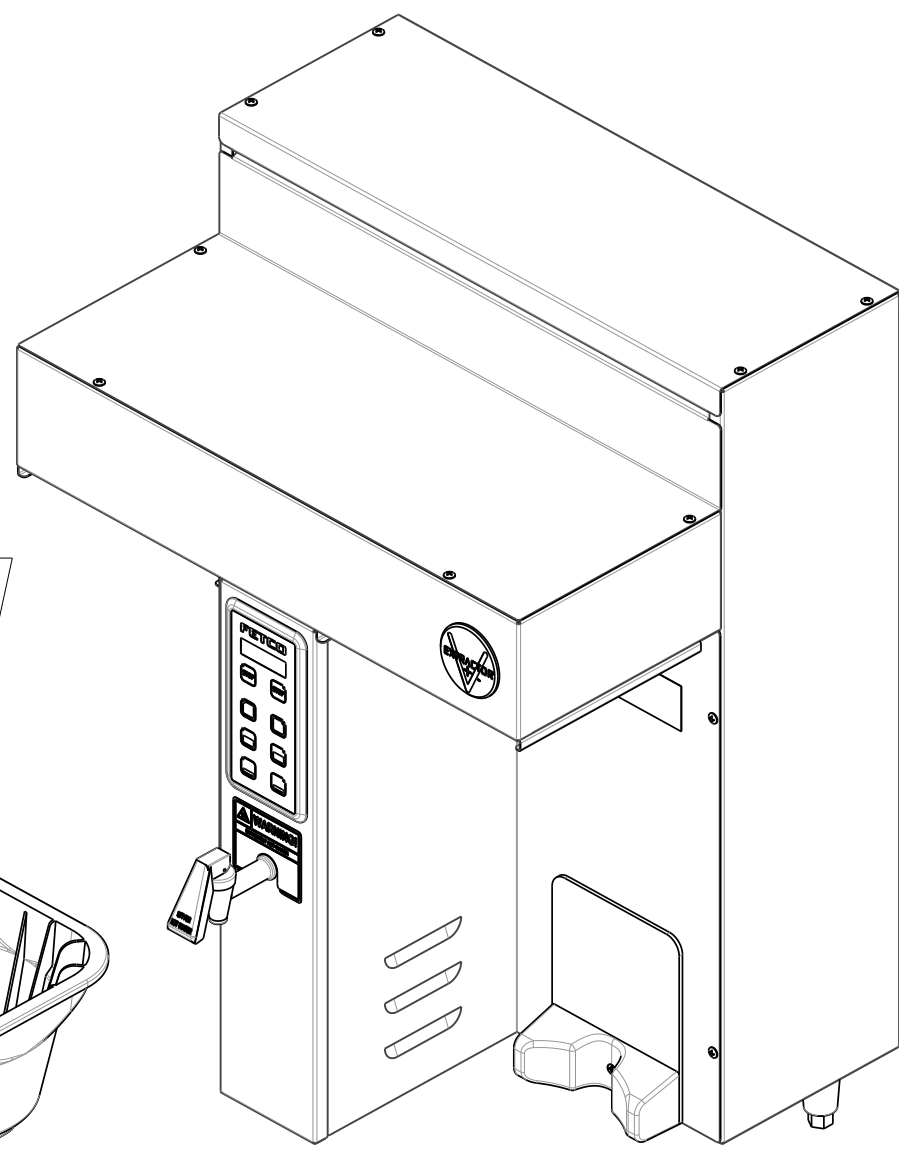
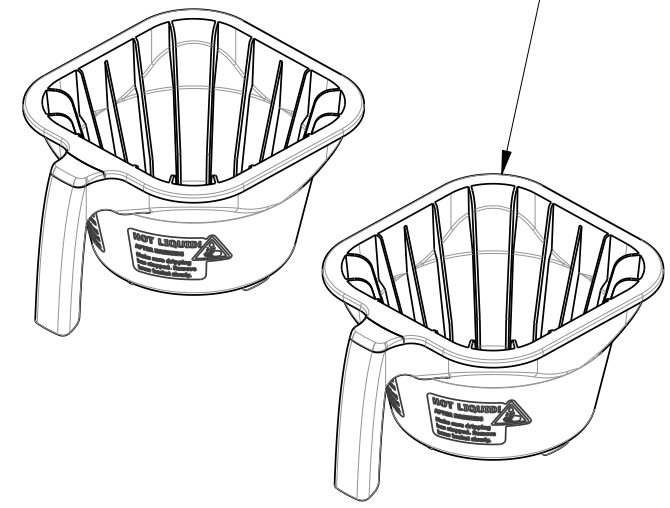

3X 1073.00016.00
 LEG, THERMOPLASTIC,
 2.50" (63mm)

1401.00158.00
 WIRING DIAGRAM
 UNIVERSAL, 2 HEATERS, CE

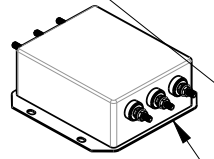

1052.00027.00
 EMI FILTER
 THREE LINE 30A
 250/440VAC

1086.00029.00
 CONNECTOR CLAMP

2X 1087.00002.00
 RIVET, BLIND DOMED

1003.00348.00
 ADAPTER PLATE
 STRAIN RELIEF, CE

1044.00013.00
 LABEL, EQUIPOTENTIALITY, CE

1084.00006.00
 #8-32 HEX NUT

1083.00011.00
 #8 INT. TOOTH WASHER

1065.00009.00
 GROUND LUG CONNECTOR

1104.00057.01
 TANK ASSEMBLY, CBS-1132 XV+
 2 x 2.3kW/240VAC

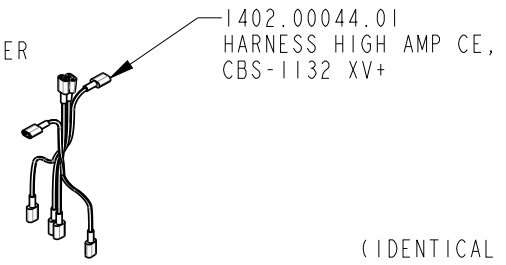

1402.00044.01
 HARNESS HIGH AMP CE,
 CBS-1132 XV+

E113264 & E113264M
 (IDENTICAL TO 1101.00340.00 EXCEPT AS NOTED)

| TOLERANCES | | FETCO® FOOD EQUIPMENT TECHNOLOGIES COMPANY | |
|---------------------------------------|--------------|---|--------------------|
| UNLESS OTHERWISE SPECIFIED | | 600 ROSE ROAD, LAKE ZURICH, IL 60047, USA PHONE: (800) 338-2699 FAX: (847) 719-3001 E-MAIL: engineering@fetco.com www.fetco.com | |
| ALL DIMENSIONS IN INCHES | | DRAWING NAME: CBS-1132-XV†, 2Ph, 2L,N,PE, 2 X 2.3kW/240VAC, 230/400VAC, CE | |
| ALL DECIMAL ± .005" ANGULAR ± 1/2° | THIRD-ANGLE | CREATED BY: DK | DATE 06/27/2016 |
| | | DRAWING BY: E. FORONDA | SCALE 0.188 |
| | | APP'D BY: AG | SHEETS 8 of 11 |
| MATERIAL N/A | GAUGE N/A | DRAWING NO. E113264 | |
| | | FINISH N/A | |
| | | REVISION A | |

PROPRIETARY AND CONFIDENTIAL.
 THE INFORMATION CONTAINED IN THIS DRAWING IS THE SOLE PROPERTY OF FETCO.
 ANY REPRODUCTION IN PART OR AS A WHOLE WITHOUT THE WRITTEN PERMISSION OF FETCO IS PROHIBITED.

| REVISIONS | | | | |
|-----------|------------|--------|-------------|-----|
| REV | DATE | ECO NO | DESCRIPTION | BY: |
| A | 06/27/2016 | N/A | ORIGINAL | DK |

A

SKU # E113266 - 2X B014218BN2 (BROWN PLUG)
 SKU # E113266M - 2X B003218B1 (BLACK HANDLE)
 BB ASSY, 13" X 5", Ø.218" HOLE

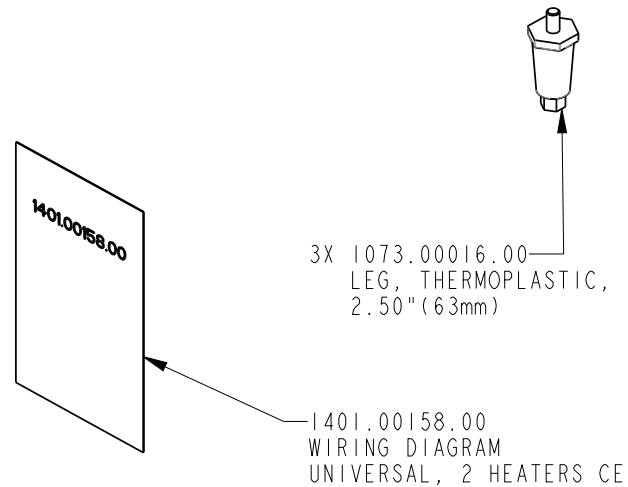
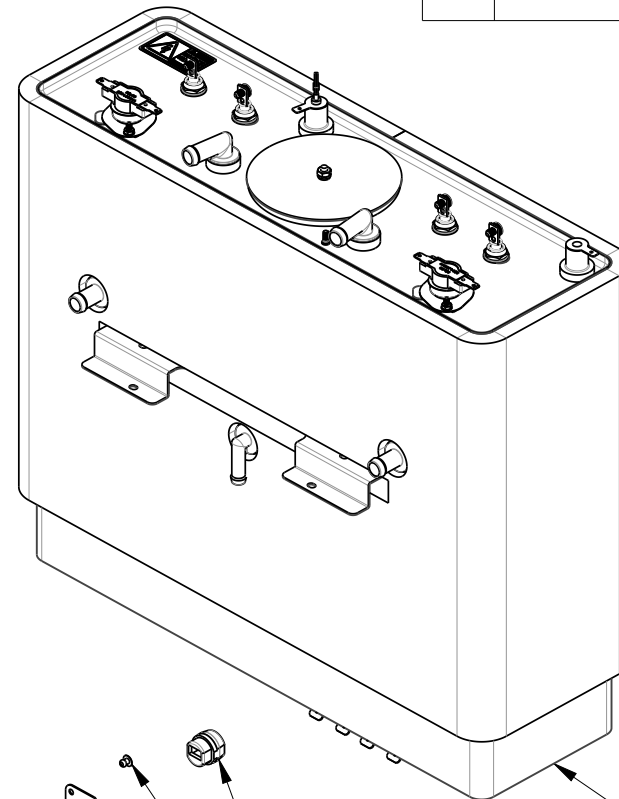
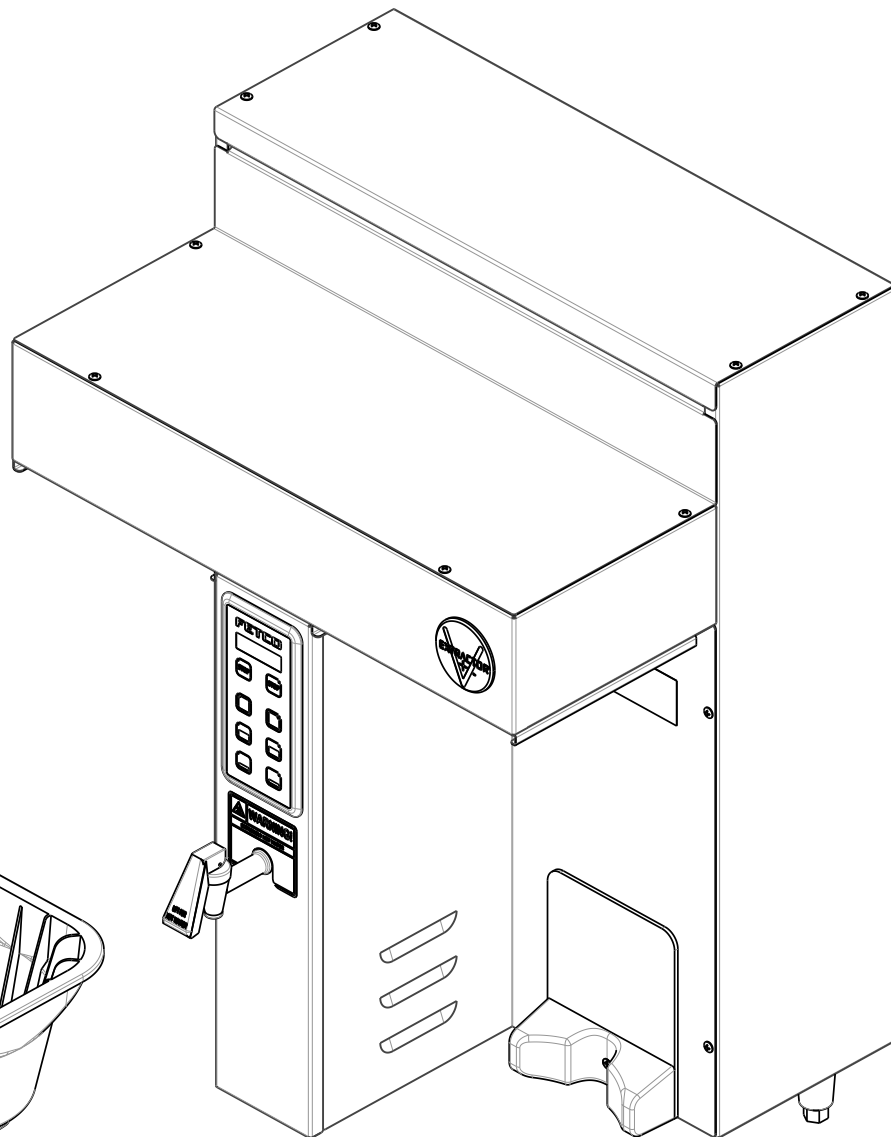
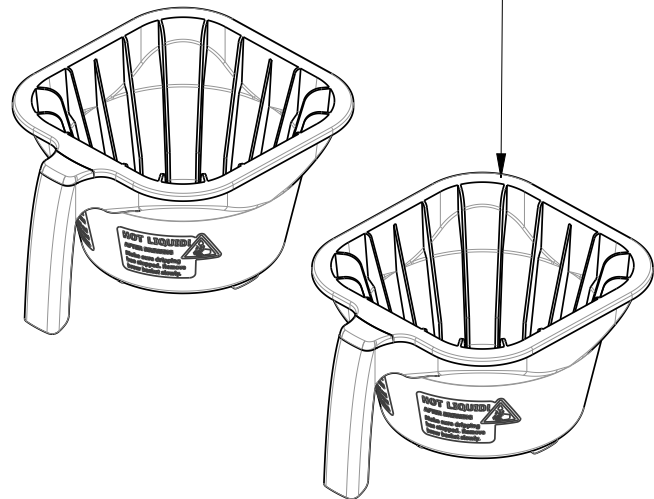

3X 1073.00016.00
 LEG, THERMOPLASTIC,
 2.50" (63mm)

1401.00158.00
 WIRING DIAGRAM
 UNIVERSAL, 2 HEATERS CE

- 1086.00029.00
CONNECTING CLAMP
- 1104.00052.01
TANK ASSEMBLY, CBS-1132 XV+
2 x 3kW/240VAC
- 2X 1087.00002.00
RIVET, BLIND DOMED
- 1003.00348.00
ADAPTER PLATE
STRAIN RELIEF, CE
- 1044.00013.00
LABEL, EQUIPOTENTIALITY, CE
- 1084.00006.00
#8-32 HEX NUT
- 1083.00011.00
#8 INT. TOOTH WASHER
- 1402.00044.01
HARNESS HIGH AMP CE,
CBS-1132 XV+
- 1065.00009.00
GROUND LUG CONNECTOR
- 4X 1084.00012.00
#6-32 HEX NUT
- 4X 1083.00009.00
#6 INT. TOOTH WASHER
- 1052.00027.00
EMI FILTER
THREE LINE 30A
250/440VAC

E113266 & E113266M
 (IDENTICAL TO 1101.00340.00 EXCEPT AS NOTED)

PROPRIETARY AND CONFIDENTIAL.
 THE INFORMATION CONTAINED IN THIS DRAWING IS THE SOLE PROPERTY OF FETCO.
 ANY REPRODUCTION IN PART OR AS A WHOLE WITHOUT THE WRITTEN PERMISSION OF FETCO IS PROHIBITED.

| TOLERANCES | | FETCO® FOOD EQUIPMENT TECHNOLOGIES COMPANY | |
|---------------------------------------|--------------|---|---------------------|
| UNLESS OTHERWISE SPECIFIED | | 600 ROSE ROAD, LAKE ZURICH, IL 60047, USA PHONE: (800) 338-2699 FAX: (847) 719-3001 E-MAIL: engineering@fetco.com www.fetco.com | |
| ALL DIMENSIONS IN INCHES | | DRAWING NAME: CBS-1132 XV+, 1Ph, L,N,PE, 2 X 3kW/240VAC, 230VAC, CE | |
| ALL DECIMAL ± .005" ANGULAR ± 1/2° | THIRD-ANGLE | CREATED BY: DK | DATE: 06/27/2016 |
| | | DRAWING BY: E. FORONDA | SCALE: 0.188 |
| | | APP'D BY: AG | SHEETS: 9 of 11 |
| MATERIAL N/A | GAUGE N/A | FINISH N/A | |

| REVISIONS | | | | |
|-----------|------------|--------|-------------|-----|
| REV | DATE | ECO NO | DESCRIPTION | BY: |
| A | 06/27/2016 | N/A | ORIGINAL | DK |

A

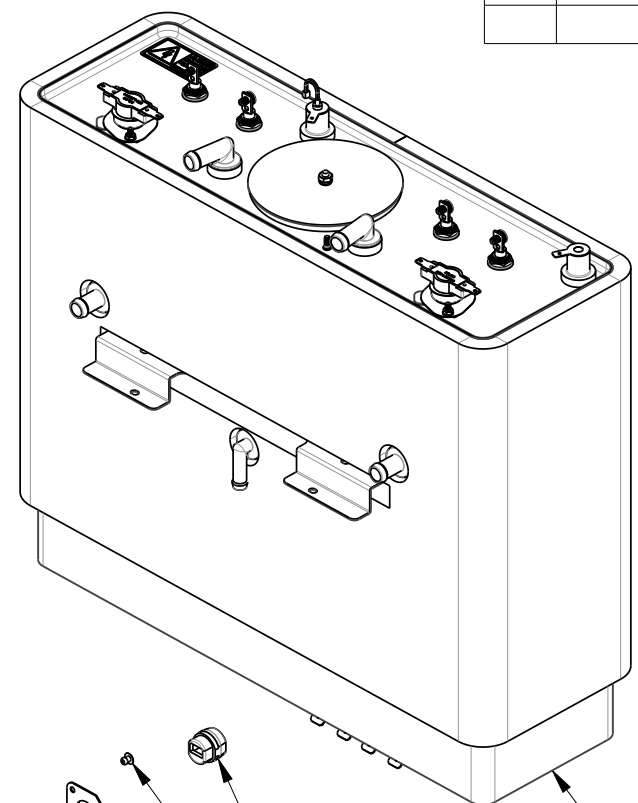
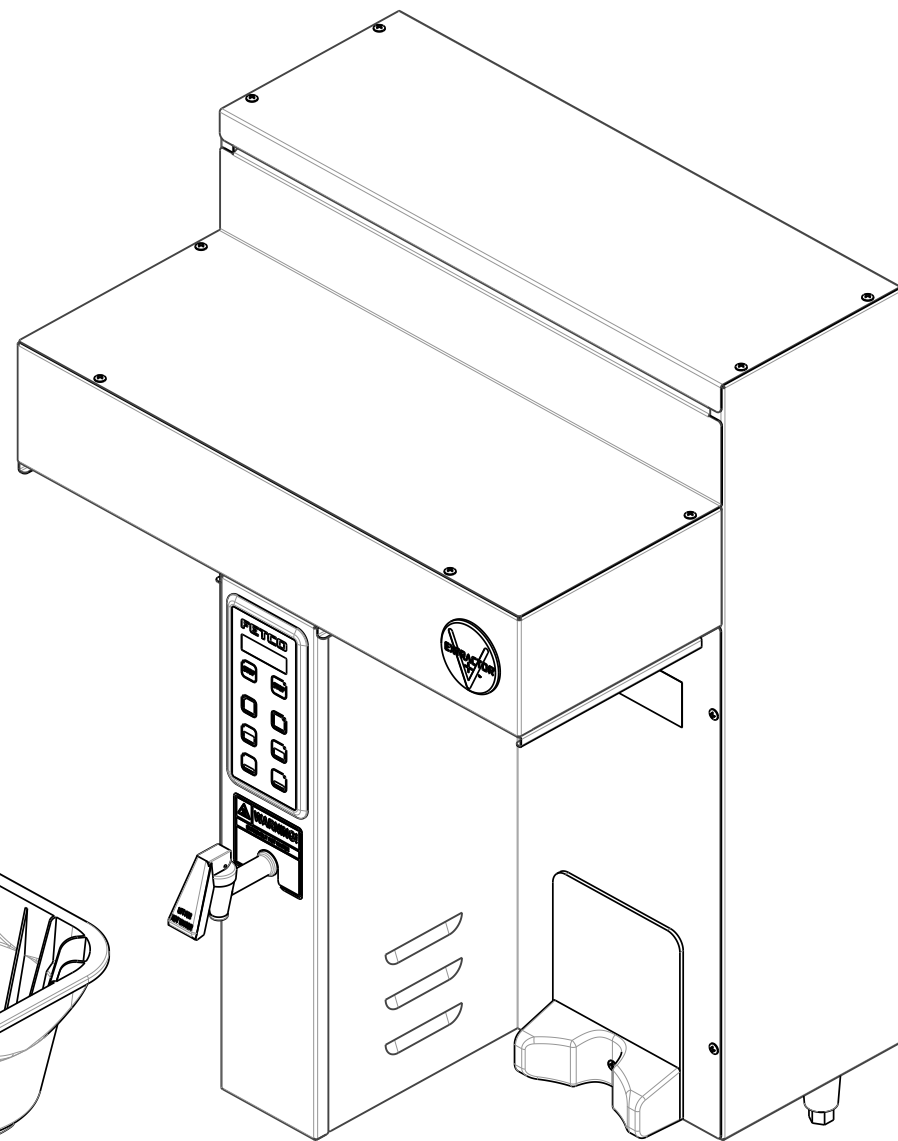

SKU # E113268 - 2X B014218BN2 (BROWN PLUG)
 SKU # E113268M - 2X B003218B1 (BLACK HANDLE)
 BB ASSY, 13" X 5", Ø.218" HOLE

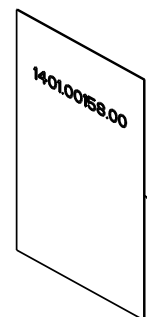
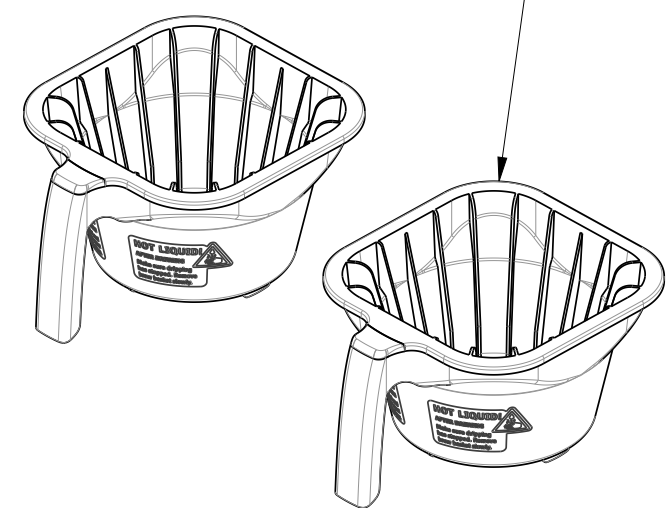

3X 1073.00016.00
 LEG, THERMOPLASTIC,
 2.50" (63mm)

1401.00158.00
 WIRING DIAGRAM
 UNIVERSAL, 2 HEATERS, CE

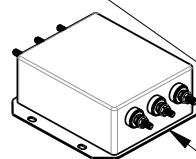

1052.00027.00
 EMI FILTER
 THREE LINE 30A
 250/440VAC

- 1086.00029.00
CONNECTOR CLAMP
- 2X 1087.00002.00
RIVET, BLIND DOME
- 1003.00348.00
ADAPTER PLATE
STRAIN RELIEF, CE
- 1044.00013.00
LABEL, EQUIPOTENTIALITY, CE
- 1084.00006.00
#8-32 HEX NUT
- 1083.00011.00
#8 INT. TOOTH WASHER
- 1065.00009.00
GROUND LUG CONNECTOR
- 4X 1084.00012.00
#6-32 HEX NUT
- 4X 1083.00009.00
#6 INT. TOOTH WASHER

1104.00057.01
 TANK ASSEMBLY, CBS-1132 XV+
 2 x 2.3kW/240VAC

1402.00044.01
 HARNESS HIGH AMP CE,
 CBS-1132 XV+

E113268 & E113268M
 (IDENTICAL TO 1101.00340.00 EXCEPT AS NOTED)

| TOLERANCES | | FETCO® FOOD EQUIPMENT TECHNOLOGIES COMPANY | |
|---|---------------------------|---|-------------------------------|
| UNLESS OTHERWISE SPECIFIED | | 600 ROSE ROAD, LAKE ZURICH, IL 60047, USA PHONE: (800) 338-2699 FAX: (847) 719-3001 E-MAIL: engineering@fetco.com www.fetco.com | |
| DRAWING NAME: CBS-1132 XV+, 1Ph, L,N,PE, 2 X 2.3kW/240VAC, 230VAC, CE | | | |
| ALL DIMENSIONS IN INCHES | CREATED BY: DK | DATE 06/27/2016 | DRAWING NO. E113268 |
| ALL DECIMAL ± .005" ANGULAR ± 1/2° | DRAWING BY: E. FORONDA | SCALE 0.188 | REVISION A |
| THIRD-ANGLE | APP'D BY: AG | SHEETS 10 of 11 | |
| MATERIAL N/A | GAUGE N/A | FINISH N/A | |

PROPRIETARY AND CONFIDENTIAL.
 THE INFORMATION CONTAINED IN THIS DRAWING IS THE SOLE PROPERTY OF FETCO.
 ANY REPRODUCTION IN PART OR AS A WHOLE WITHOUT THE WRITTEN PERMISSION OF FETCO IS PROHIBITED.

| REVISIONS | | | | |
|-----------|------------|--------|-------------|-----|
| REV | DATE | ECO NO | DESCRIPTION | BY: |
| A | 06/27/2016 | N/A | ORIGINAL | DK |

A

SKU # E113291 - 2X B014218BN2 (BROWN PLUG)
 SKU # E113291M - 2X B003218B1 (BLACK HANDLE)
 BB ASSY, 13" X 5", Ø.218" HOLE

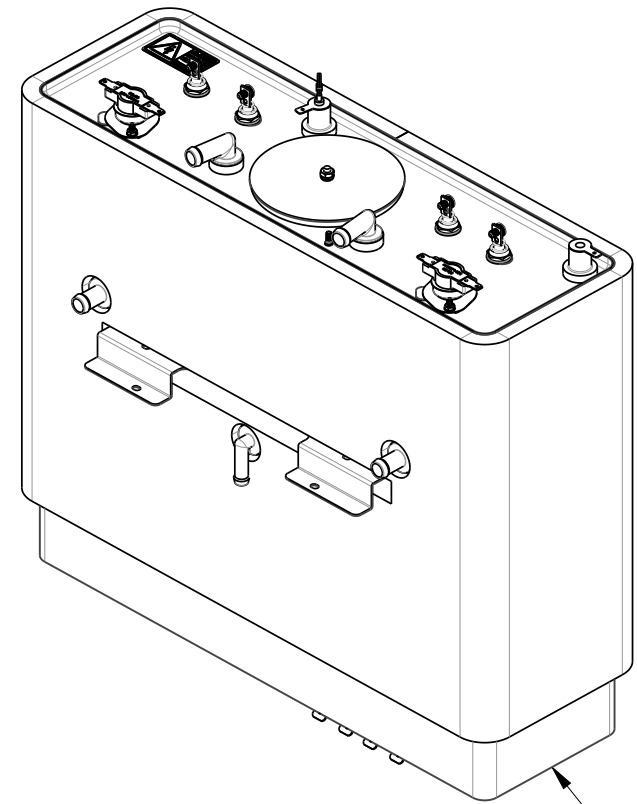
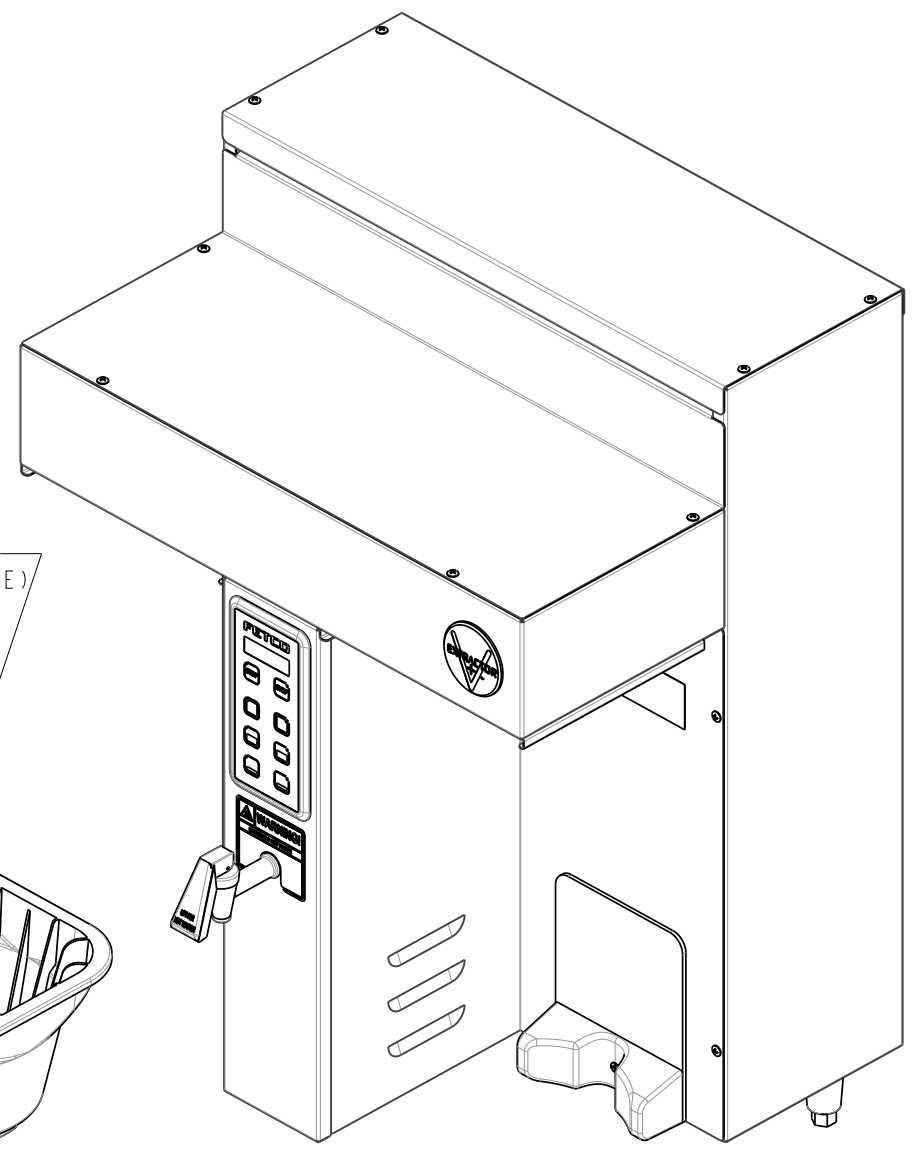
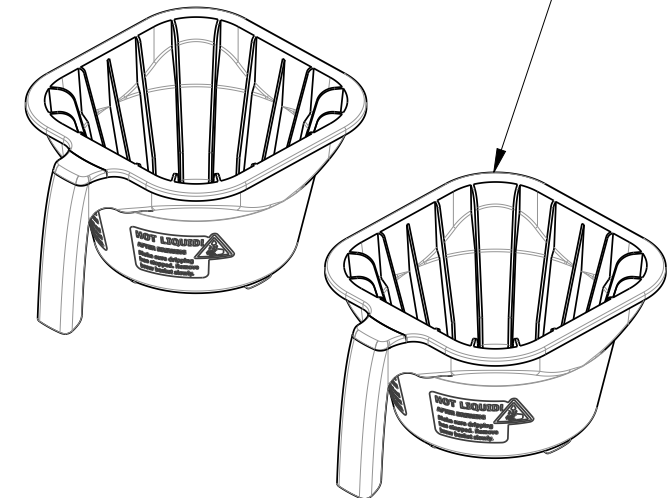

1086.00008.00
CONNECTOR CLAMP

1104.00052.01
TANK ASSEMBLY, CBS-1132 XV+
2 x 3kW/240VAC



1401.00149.00
WIRING, CBS-1132 XV+,
L1, N, GND, 2 HEATERS

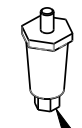

3X 1073.00016.00
LEG, THERMOPLASTIC,
2.50" (63mm)

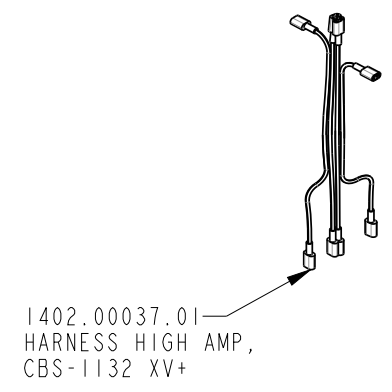

1402.00037.01
HARNESS HIGH AMP,
CBS-1132 XV+

E113291 & E113191M
 (IDENTICAL TO 1101.00340.00 EXCEPT AS NOTED)

| TOLERANCES | | FETCO® FOOD EQUIPMENT TECHNOLOGIES COMPANY | |
|---------------------------------------|--------------|---|--------------------|
| UNLESS OTHERWISE SPECIFIED | | 600 ROSE ROAD, LAKE ZURICH, IL 60047, USA PHONE: (800) 338-2699 FAX: (847) 719-3001 E-MAIL: engineering@fetco.com www.fetco.com | |
| ALL DIMENSIONS IN INCHES | | DRAWING NAME: CBS-1132 XV+, 1Ph, 2IG, 2 X 3.0kW/240VAC, 200-240VAC, INTL | |
| ALL DECIMAL ± .005" ANGULAR ± 1/2° | THIRD-ANGLE | CREATED BY: DK | DATE 06/27/2016 |
| | | DRAWING BY: E. FORONDA | SCALE 0.188 |
| | | APP'D BY: AG | SHEETS 11 of 11 |
| MATERIAL N/A | GAUGE N/A | DRAWING NO. E113291 | |
| | | REVISION A | |
| | | FINISH N/A | |

PROPRIETARY AND CONFIDENTIAL.
 THE INFORMATION CONTAINED IN THIS DRAWING IS THE SOLE PROPERTY OF FETCO.
 ANY REPRODUCTION IN PART OR AS A WHOLE WITHOUT THE WRITTEN PERMISSION OF FETCO IS PROHIBITED.